



SR EB4

1/8 Nitro Powered 4WD Racing Buggy



No.6230-K10



Please read all instructions thoroughly before assembling the kit.

The contents are subject to change without prior notice due to product improvements and specification changes.

INSTRUCTION MANUAL

WARRANTY

Thunder Tiger Corporation guarantees this model kit to be free from defects in both material and workmanship. The total monetary value under warranty will in no case exceed the cost of the original kit purchased. This warranty does not cover any components damaged by use or modification. Part or parts missing from this kit must be reported within 60 days of purchase. No part or parts will be sent under warranty without proof of purchase. To receive part or parts under warranty, the service center must receive a proof of purchase and/or the defective part or parts. Should you find a defective or missing part, contact the authorized Thunder Tiger Service/Distributor nearest you. Under no circumstances can a dealer or distributor accept return of a kit if assembly has started.



INTRODUCTION

The Thunder Tiger EB-4 S3 was designed as a whole new off-road 4WD nitro-racing buggy, especially on a high-speed and bumpy off-road track. There's no doubt that the innovation would be the very first priority of our design team. We have set this buggy far ahead of the current form of existing buggy design in the market in terms of the future designing trend. The new EB-4 S3 comes with some totally new settings that have never been applied on 1/8th scale nitro buggy before, such as the super low center of gravity, radical engineering of a car construction and more than innovative, good looking and high performance suspension. This is a look into the future for 1/8th scale cars and the future is here with Thunder Tiger. However there is no compromise between the innovation and quality. Thunder Tiger guarantees you should have many hours of trouble free use from this R/C product. We race and test our products around the world to bring you state-of-the-art R/C products.

CAUTION

Thank you for purchasing a Thunder Tiger Product.

Please read all instructions and familiarize yourself with the products and controls before operation.

1. This product is not a toy. It is a high performance model product. It is important to familiarize yourself with the model, its manual, and its construction before assembly or operation. A child operating under the supervision of the adults is necessary.
2. Always keep this instruction manual ready at your hand for your assembling and operating reference, even after completing the assembly.
3. Make sure all the screws are properly tightened and all the parts are checked after running the car for a long period of time.
4. For the best performance, it is important to make sure all the moveable parts work free without binding.
5. Do not operate model products in rain, on public roads, near crowds, near airport, or near areas with restricted radio operation.
6. Always keep fuel away from heat and open flame. Only operate in open, well-ventilated area. Store fuel in cool, dry area. Keep the fuel bottle cap tightly closed. Clean up any leak or excess fuel before starting the engine.
7. This product, its parts, and its construction tools can be harmful to your health. Always exercise extreme caution when assembling and/or operating this product. Do not touch any part of the model that rotates.
8. Check your radio frequency with the proper operating frequency of the area or country. Always check to see if there are any modelers operating on the same frequency as yours. Also, check your radio for proper operation before operating a model.

INDEX

INTRODUCTION	» 2	STEP 9 RADIO BOX & FUEL TANK	» 17
IMPORTANT NOTES & WARNING	» 3	STEP 10 ENGINE MOUNT & CLUTCH SET	» 19
ITEMS REQUIRED FOR ASSEMBLE	» 4	STEP 11 THROTTLE AND BRAKE LINKAGE	» 20
STEP 1 STEERING SERVO SAVER	» 5	STEP 12 AIR FILTER	» 22
STEP 2 GEAR DIFFERENTIALS	» 7	STEP 13 SHOCK ABSORBERS	» 23
STEP 3 FRONT & REAR BULKHEAD	» 8	STEP 14 REAR WING	» 24
STEP 4 CENTER DIFF MOUNT & BRAKE	» 9	STEP 15 WHEEL AND TIRE	» 26
STEP 5 CENTER DRIVE TRAIN	» 11	STEP 16 BODY	» 26
STEP 6 FRONT SUSPENSION	» 12	SET UP	» 27
STEP 7 REAR SUSPENSION	» 14	SET UP SHEET	» 31
STEP 8 SIDE GUARD	» 16		

IMPORTANT NOTES & WARNING

FUEL SELECTION



1. Choose a fuel from a reputable, brand name company that is approved for car/truck use. Do not use airplane or boat fuels in your car/truck. Choose methanol based model engine glow fuel that has a nitro content in the range 10%-30% and 5% to 18% castor/synthetic oil content for lubrication. Lower nitro percentages will generally result in a cooler engine running temperature and therefore last longer before needing a rebuild; cooler-running engines also generally produce less power. 20% nitro is the most widely used fuel.
2. Fuel color is for identification purpose only and is not important to performance or durability of your engine.
3. Be careful. If the tank overflows it might get on your radio gear or on your brakes and it may create an unsafe driving situation. Always keep your fuel bottle closed when not in use.
4. Do not dispose of fuel or empty fuel containers in a fire. It may possibly cause fire or explosion.

ENGINE

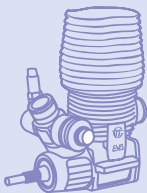

1. For proper engine break-in procedure, please refer to the manual of your engine.
2. Never run your vehicle without the air filter. If the vehicle will be operated in an area with fine dust, use filter oil or castor oil instead of fuel. It is important that the foam is only moist to trap dirt and allow air passage. With the foam too wet, limited air can pass through; therefore, limiting engine performance.
3. The parts around engine could be dangerously hot after operation. Do not touch it without any protection!

RADIO OPERATION



1. When turning radio on, first turn on the transmitter and extend the transmitter antenna.
2. Then, turn on the receiver. When turning off, first turn the receiver off, then the transmitter off.

FIRST AID



1. If you drink nitro fuel by accident, immediately drink large quantities of water and try to induce vomiting. Consult with physician right after then.
2. If the nitro fuel gets into your eyes, rinse them well with water. Consult with physician right after then.
3. If the fuel gets onto your skin, wash it well with soap and water.

WARNING



1. Improper operations may cause personal and/or property damage. Thunder Tiger and its distributor have no control over damage resulting from shipping, improper construction, or improper usage.
2. Thunder Tiger assumes and accepts no responsibility for personal and/or property damages resulting from the use of improper building materials, equipment and operations. By the act of assembling or operating this product, the user accepts all resulting liability. If the buyer is not prepared to accept this liability, then he/she should return this kit in new, unassembled, and unused condition to the place of purchase.

ITEMS REQUIRED FOR ASSEMBLY

Notice: The following items are required for completion of the EB-4 S3. Some of them are not included with this kit (unless noted), and should be obtained from the local hobby shop nearby you. (For separate purchasing products, please refer to Thunder Tiger professional R/C model products.)







1. ADDITIONAL ITEMS NEEDED FOR COMPLETION

 AA-Size Batteries for transmitter / NiCd or NiMH Battery recommended	 2 Channel Radio Set/ FM/PCM recommended	 .21 Class Rear Exhaust Engine (Ref: TTR PRO-21B-R Engine No.9474)
 Glow Plug	 Torque Digital Servo (No.8119, No.8123)	 Muffler, Joining Pipe or Manifold & Spring(Ref: TTR Muffler & Manifold No.1796, No.1797, No.1798)
 4.8V~6.0V Rx Battery Pack recommended (Flat pack)		 Tire & Inner Foam

2. ADDITIONAL ITEMS NEEDED FOR STARTING ENGINE

 Glow Fuel (Ref: R/C Model Fuel)	 Fuel Bottle	 Air Filter Oil	 Glow Starter	 Starter Box with AC/DC Power (Ref: TTR Starter Box No.2409)
---	--	---	---	--

3. TOOLS NEEDED FOR ASSEMBLY

 Phillips type screwdrivers & hex wrenches (Ref: TTR screw Drive Set)	 Hobby knife	 Needle Nose Pliers	 Wire Cutter	 Lexan Cutter/Scissors	 Special Reamer (Ref: TTR Hole Punch/ Reamer No.1120)
---	---	---	--	---	--



















4. EQUIPMENT NEEDED FOR ASSEMBLY

 CA Glue	 Screw Cement	 Silicon Oil	 Lexan Specific Spray Paint
---	--	---	--

5. TOOLS INCLUDED IN KIT

 Hex Wrench 1.5mm, 2mm, 2.5mm, 3mm, 5mm	 5-way Nut Wrench	 Wrench
--	---	--

6. SYMBOL USED THROUGHOUT THE INSTRUCTION MANUAL

 Part bag used	 Optional Parts
 Apply C.A Glue	 Cut off shaded portion
 Apply Grease	 Tentatively tighten
 Apply silicon oil	 Check out non-binding movement
 Apply screw cement	 True-to-scale diagram
 Assemble two times	 Must be purchased separately
 Assemble left and right side the same way	 Pay attention here
 Assemble in right order	 Use pliers
 Drill holes with the specified diameter (mm)	 Wire Cutter
 Hint	

1

STEERING SERVO SAVER

A
bag

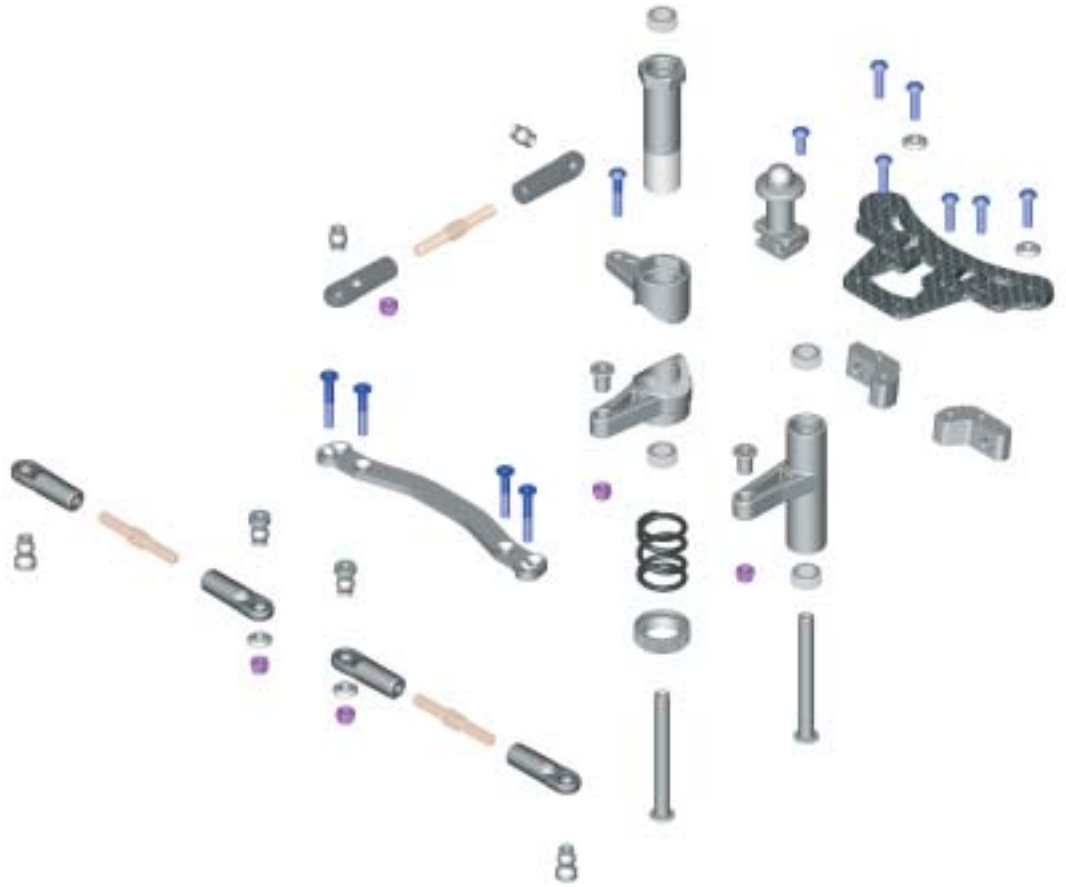

1.1



ø5x10mm
Bearing

1.2

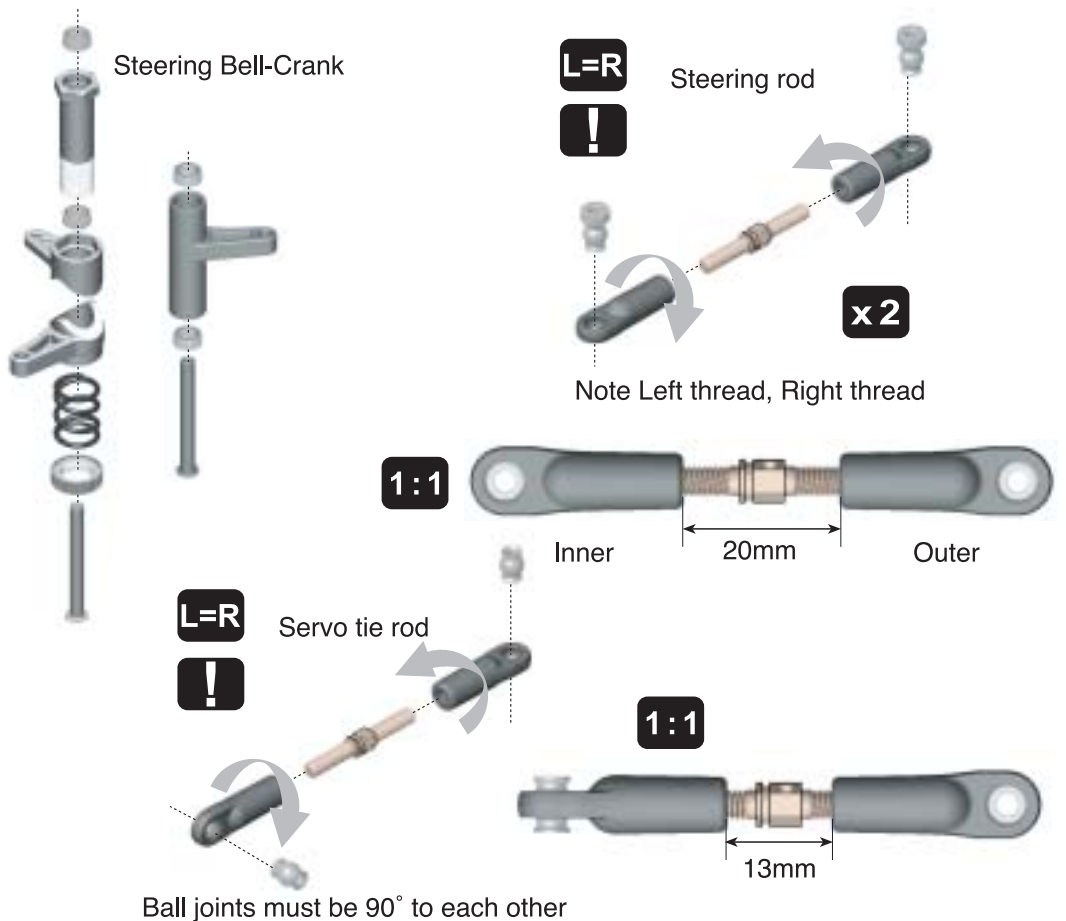

OP



PD1857 ALUM SERVO SAVER SET



1

1.3

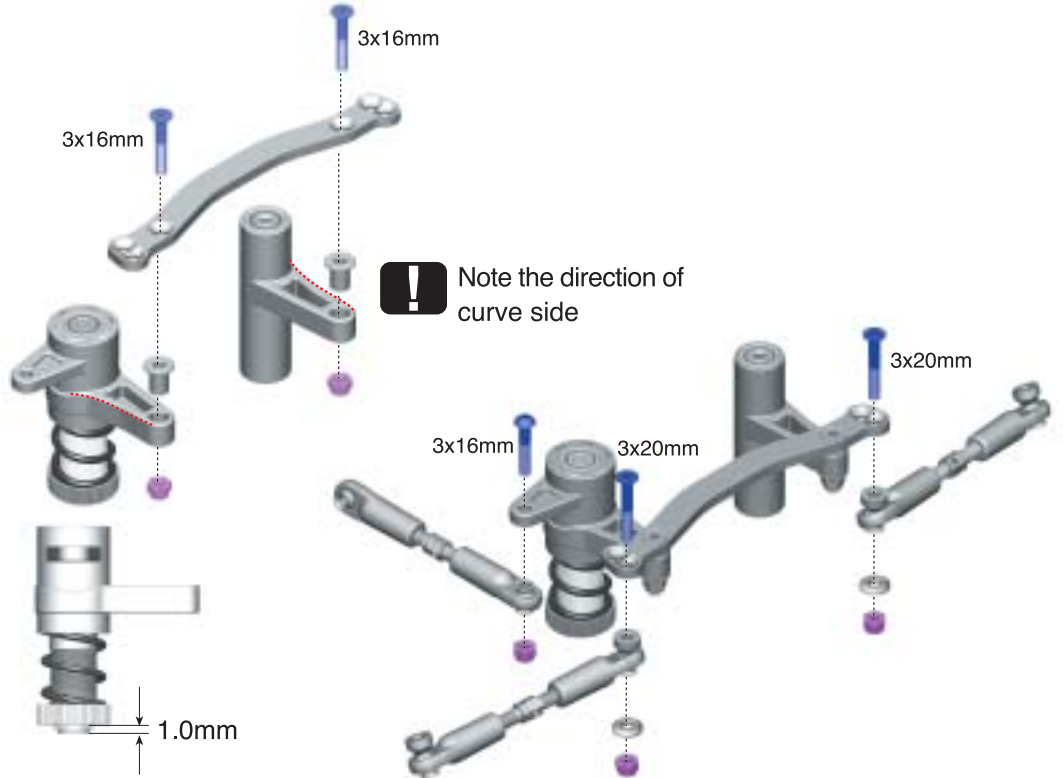
-  M3x16mm Flat Head Hex Screw
-  M3x20mm Flat Head Hex Screw
-  Lock Nut, M3
-  M3x16mm Button Head Hex Screw



1.4

-  M3x12mm Button Head Hex Screw
-  M3x8mm Button Head Hex Screw

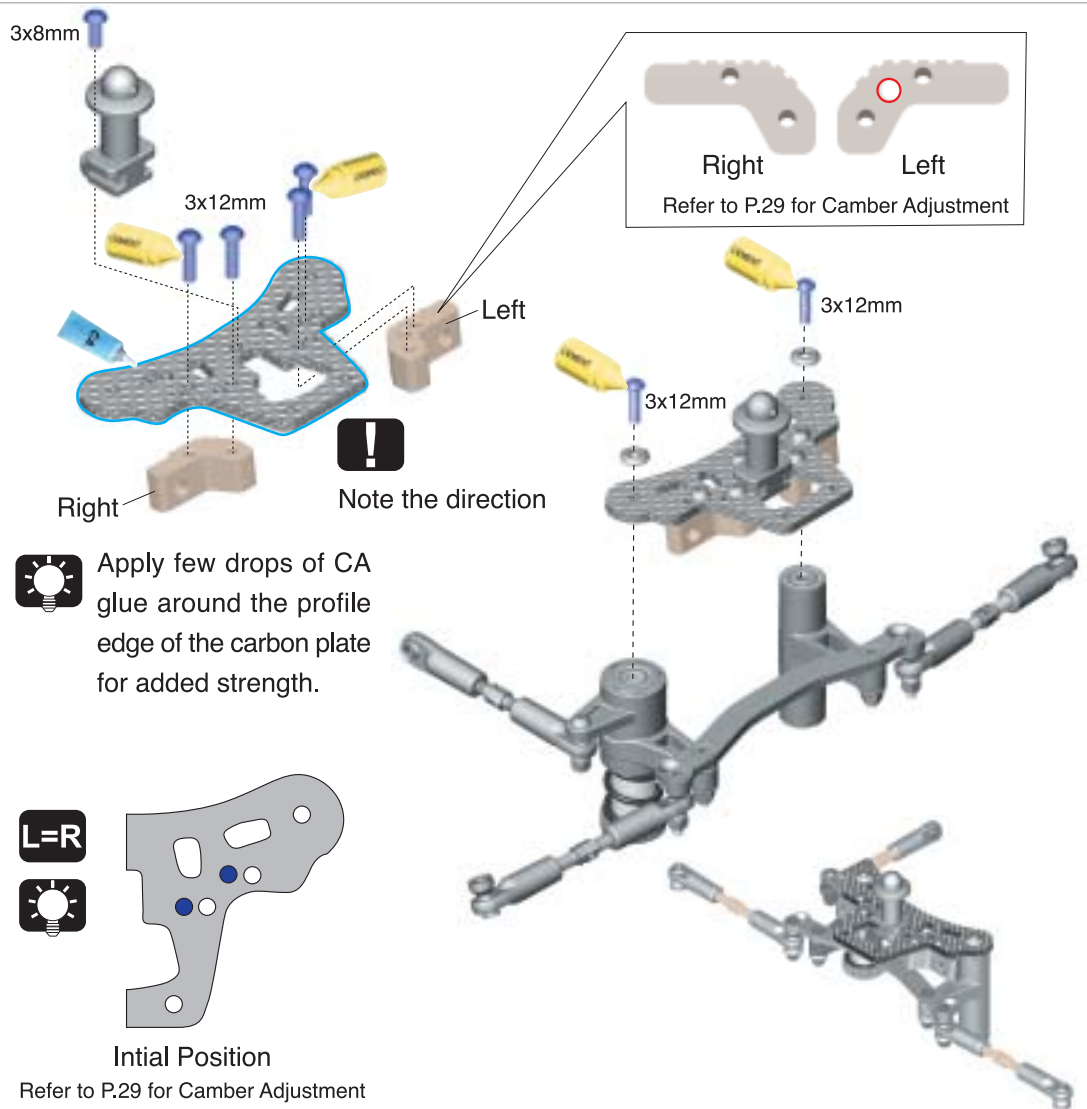

OP

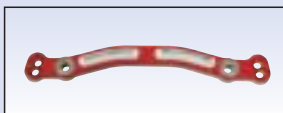

PD1858 A7075 LITE ST SLIDER W/BB

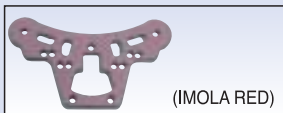

PD1843-R CARBON SERVO SAVER TOP PLATE(R) OPT

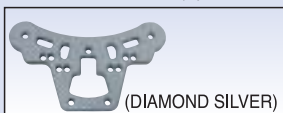

PD1843-S CARBON SERVO SAVER TOP PLATE(S) OPT

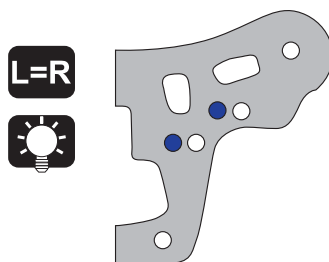

Initial Position
Refer to P.29 for Camber Adjustment

2

GEAR DIFFERENTIALS

B
bag

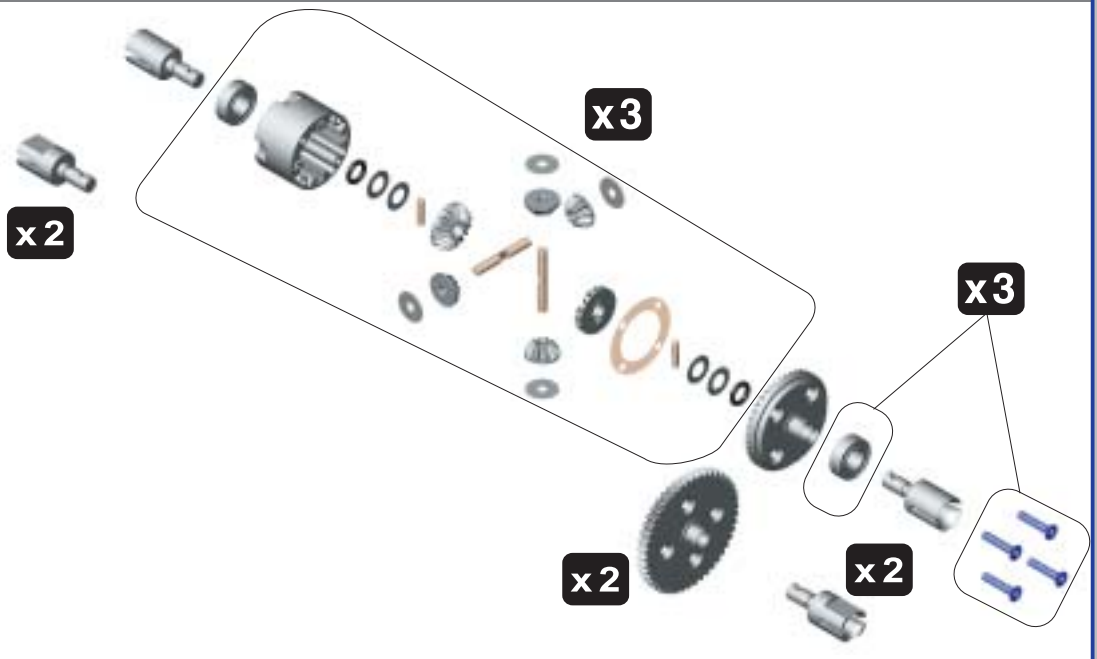

2.1



Roll Pin, $\varnothing 2.5 \times 11 \text{mm}$



O-ring, outdrive



0.15mm Gear Shim

OP

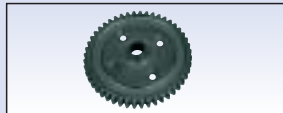

PD1998 STEEL MAIN GEAR, 48T

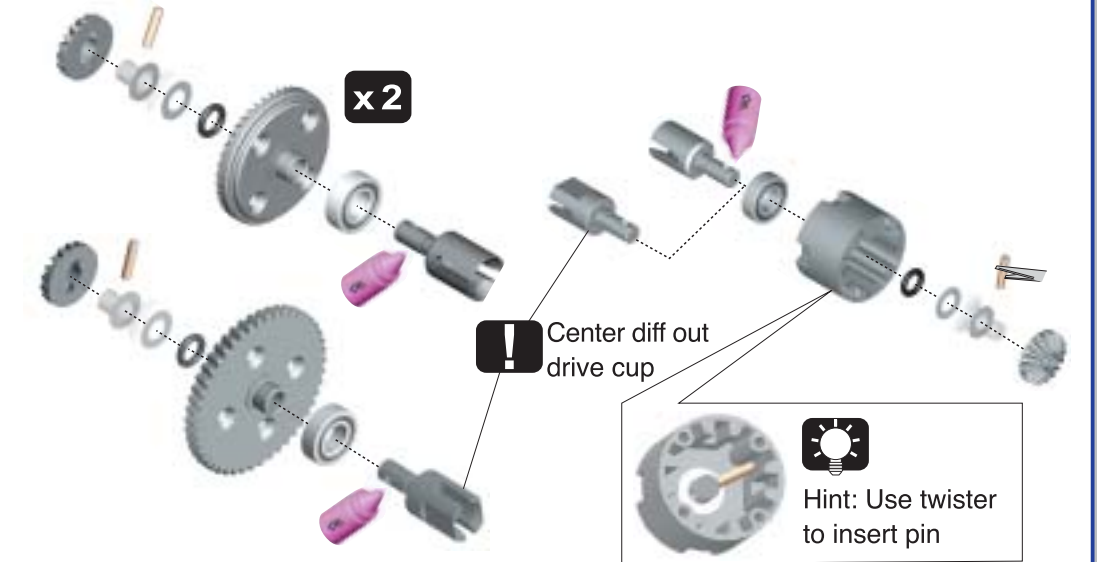

2.2



M3x14mm Flat Head Hex Screw



0.2mm Satellite Gear Shim

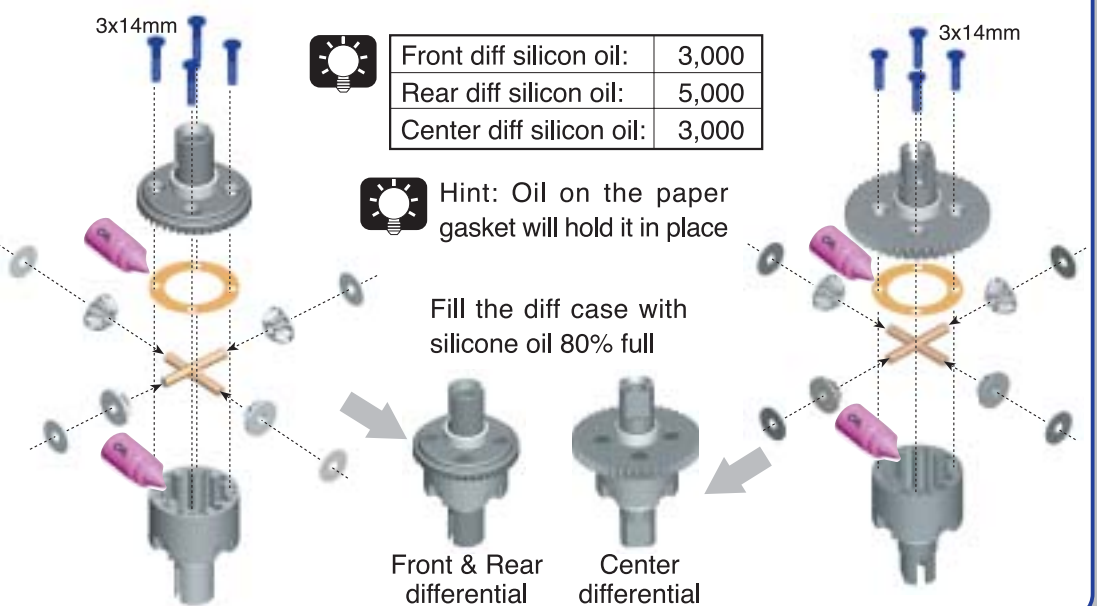

3

FRONT & REAR BULKHEADS

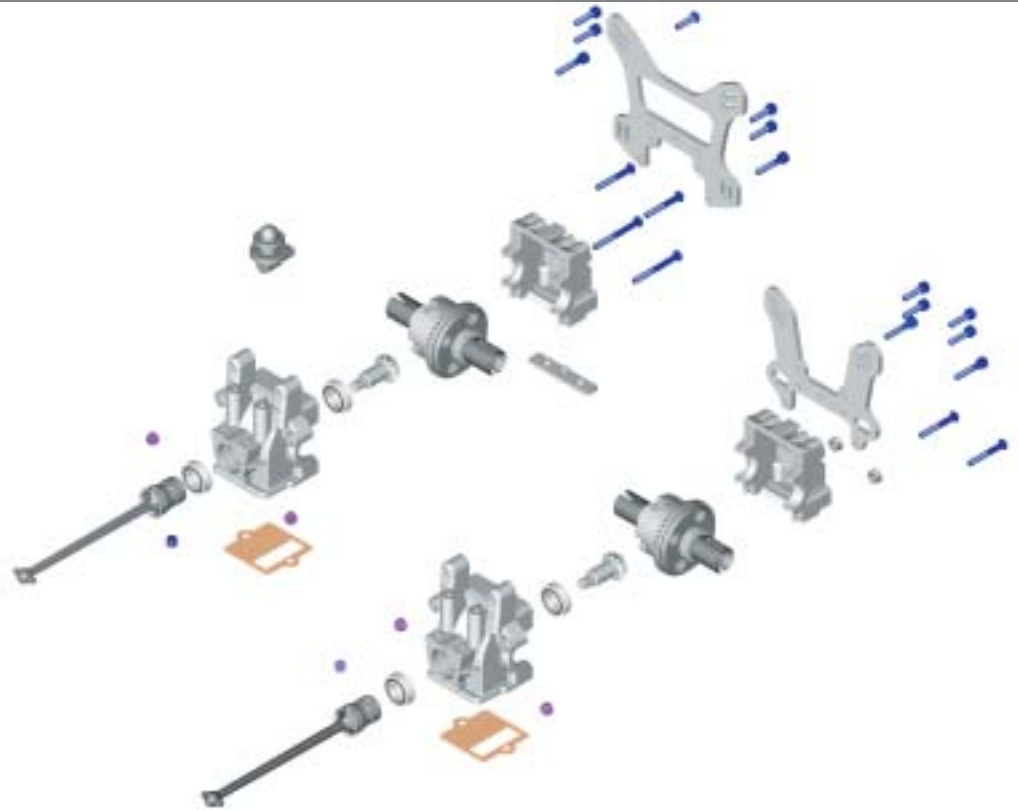

3.1

M3x22mm Button Head Hex Screw

M3x12mm Socket Head Hex Screw

M3x16mm Socket Head Hex Screw

3.2

M3x25mm Button Head Hex Screw

M3x12mm Button Head Hex Screw

M3x12mm Socket Head Hex Screw

M3x16mm Socket Head Hex Screw

Lock Nut, M3

M5x4mm Set Screw

Hint: Use supplied shims to adjust the proper gearmesh. Carefully when assembling, do not bend shims.

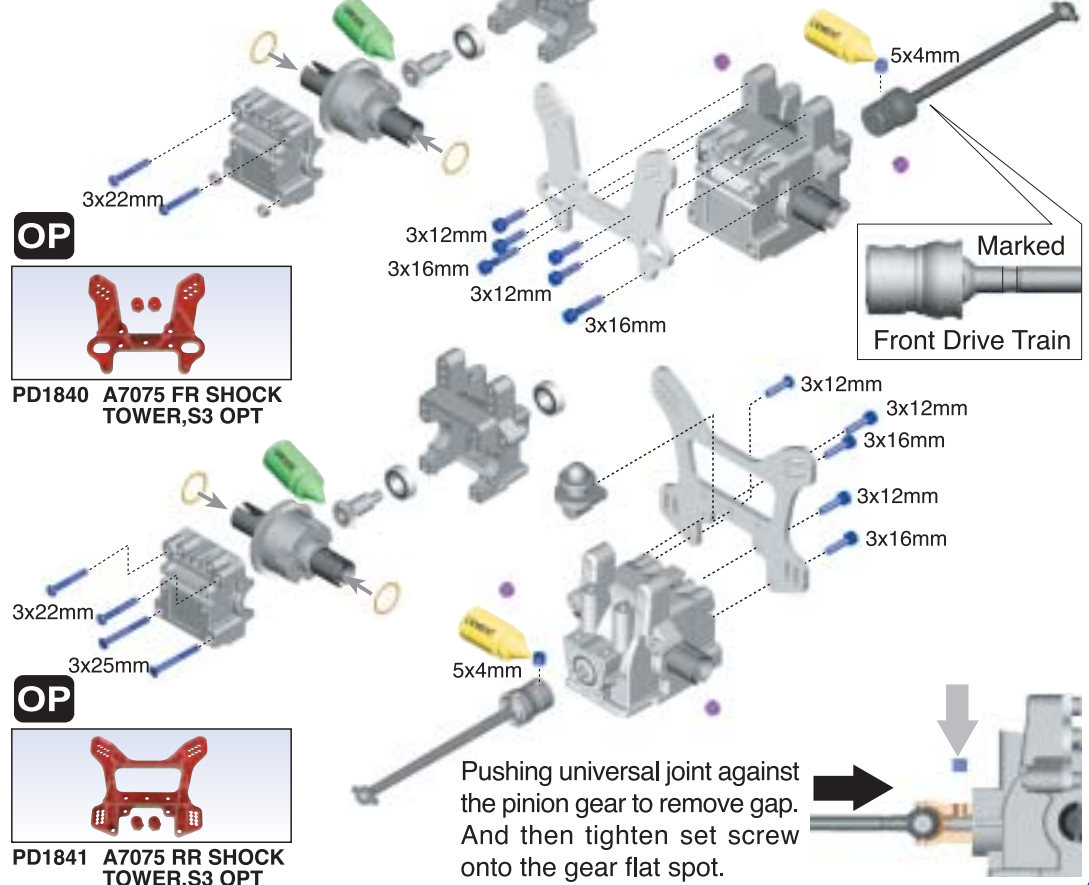

OP

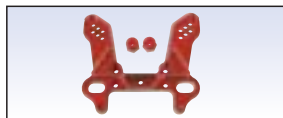

PD1840 A7075 FR SHOCK TOWER, S3 OPT

OP



PD1841 A7075 RR SHOCK TOWER, S3 OPT

4

GEAR DIFFERENTIALS

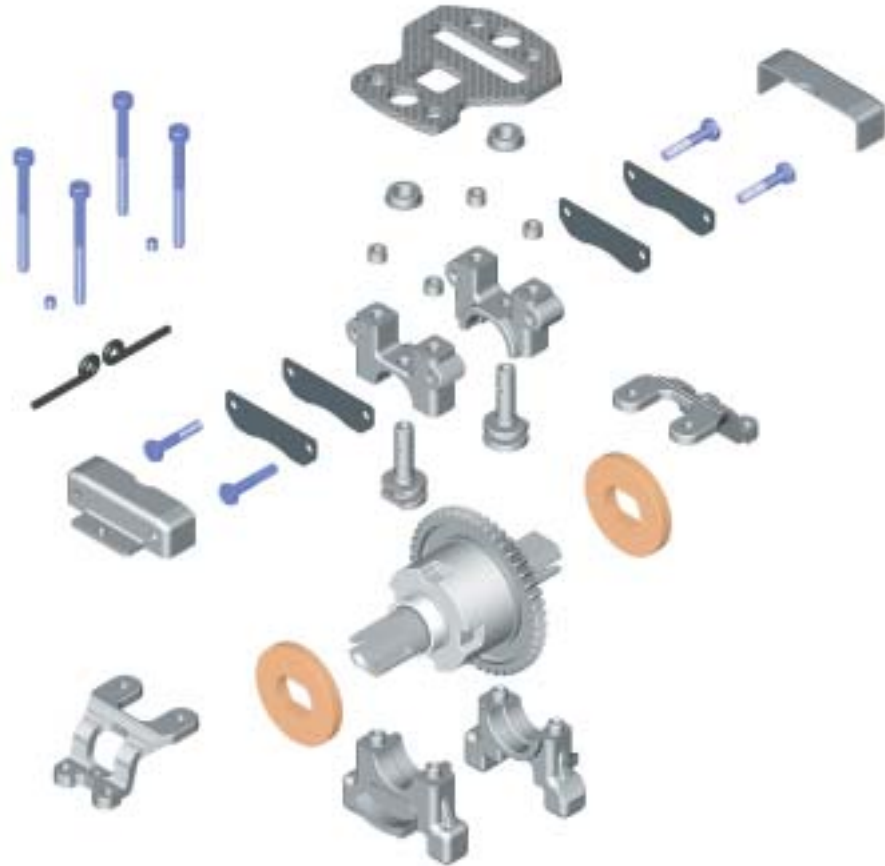

4.1



M3x16mm
Brake Pad Fixing Screw

4.2



PD1845 CTR DIFF MOUNT, S3 OPT



PD1861 HEATSINK DISC BRAKE, S3 OPT

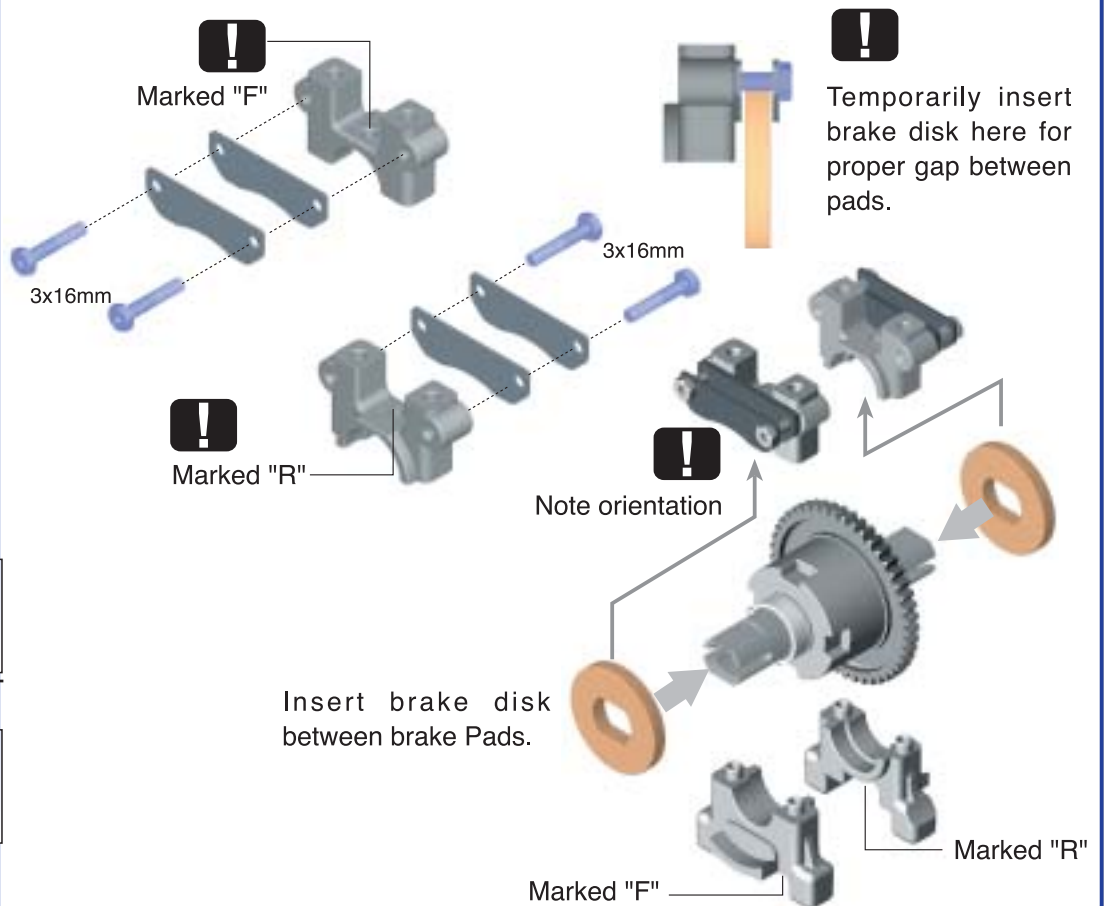

4

4.3

M3x35mm
Socket Head Hex Screw

OP

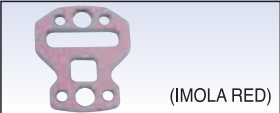

PD1844-R CARBON CTR DIFF TOP PLATE (R), S3 OPT

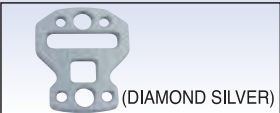

PD1844-S CARBON CTR DIFF TOP PLATE (S), S3 OPT

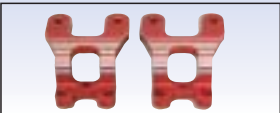

PD1846 CTR DIFF BRACE, S3 OPT

4.4

M3x3mm
Set Screw

4.5

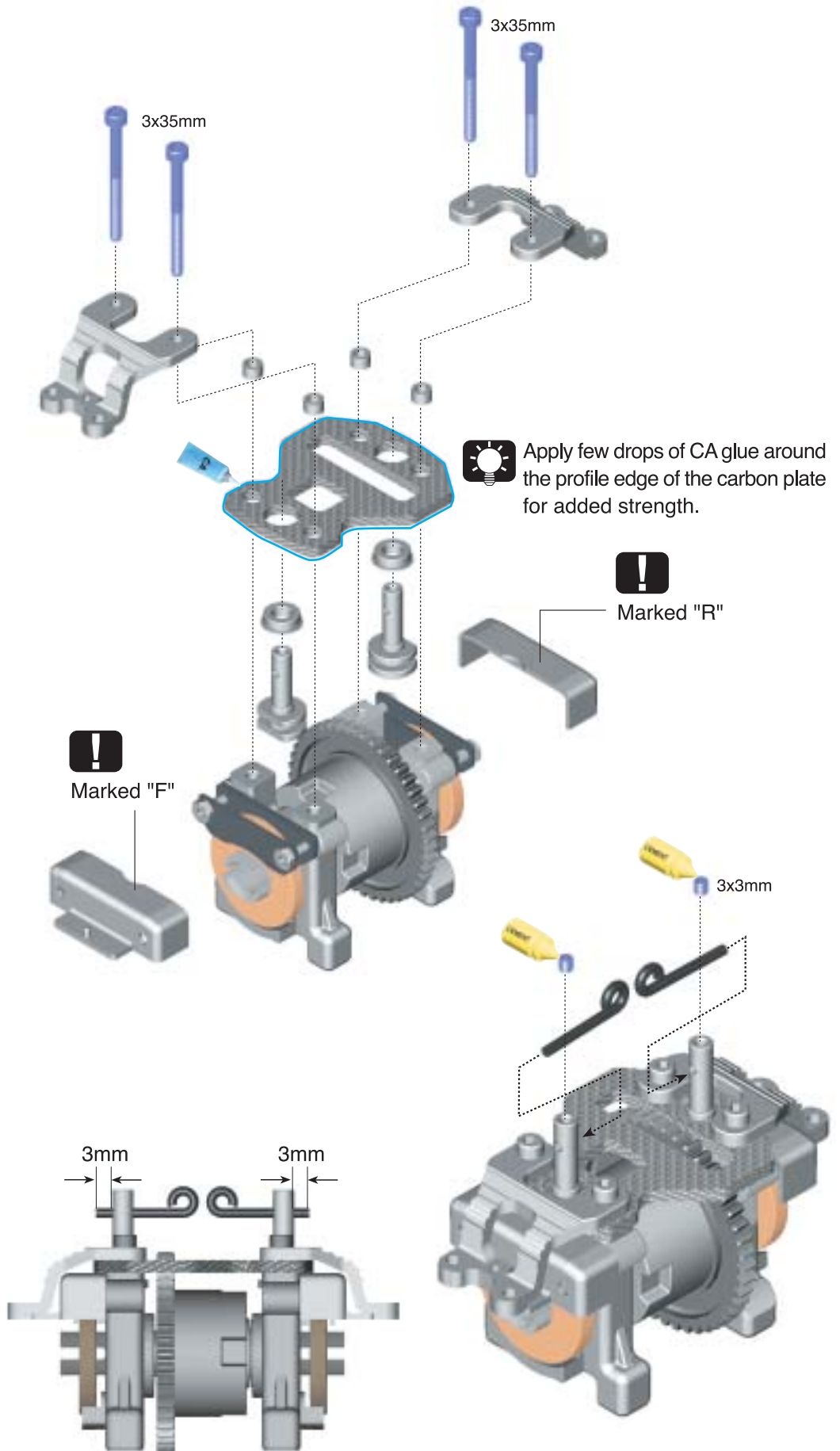

5

CENTER DRIVE TRAIN

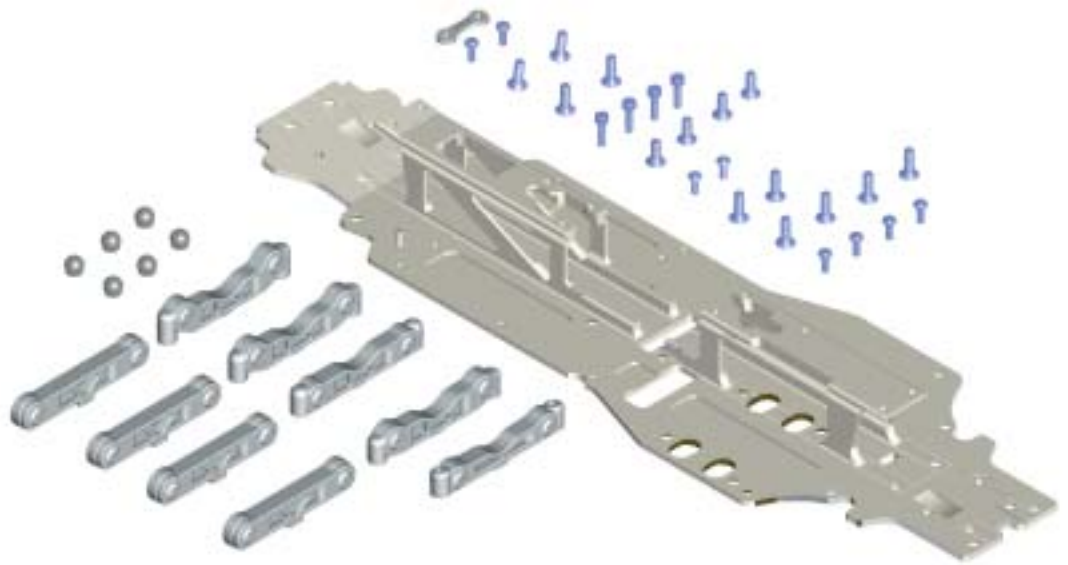

5.1

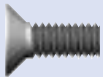

M4x10mm
Flat Head Hex Screw



M4x12mm
Flat Head Hex Screw

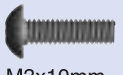

M3x10mm
Button Head Hex Screw



M3x8mm
Button Head Hex Screw

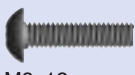

M3x12mm
Button Head Hex Screw

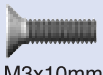

M3x10mm
Flat Head Hex Screw

OP

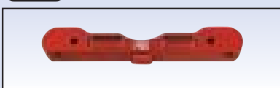

PD1850 A7075 RR PLATE RR
TRANS, FR0, S3 OPT



PD1851 A7075 FR PLATE RR
TRANS, RF0, S3 OPT



PD1852 A7075 FR PLATE RR
TRANS, RF+4, S3 OPT



Choose the FR0 toe block and RF2 toe block for the initial setting. You can adjust front caster, rear inboard toe and rear anti-squat by changing the different suspension arm holders to meet your race requirement. For more adjusting details, please refer to "Set Up" section.



Note orientation

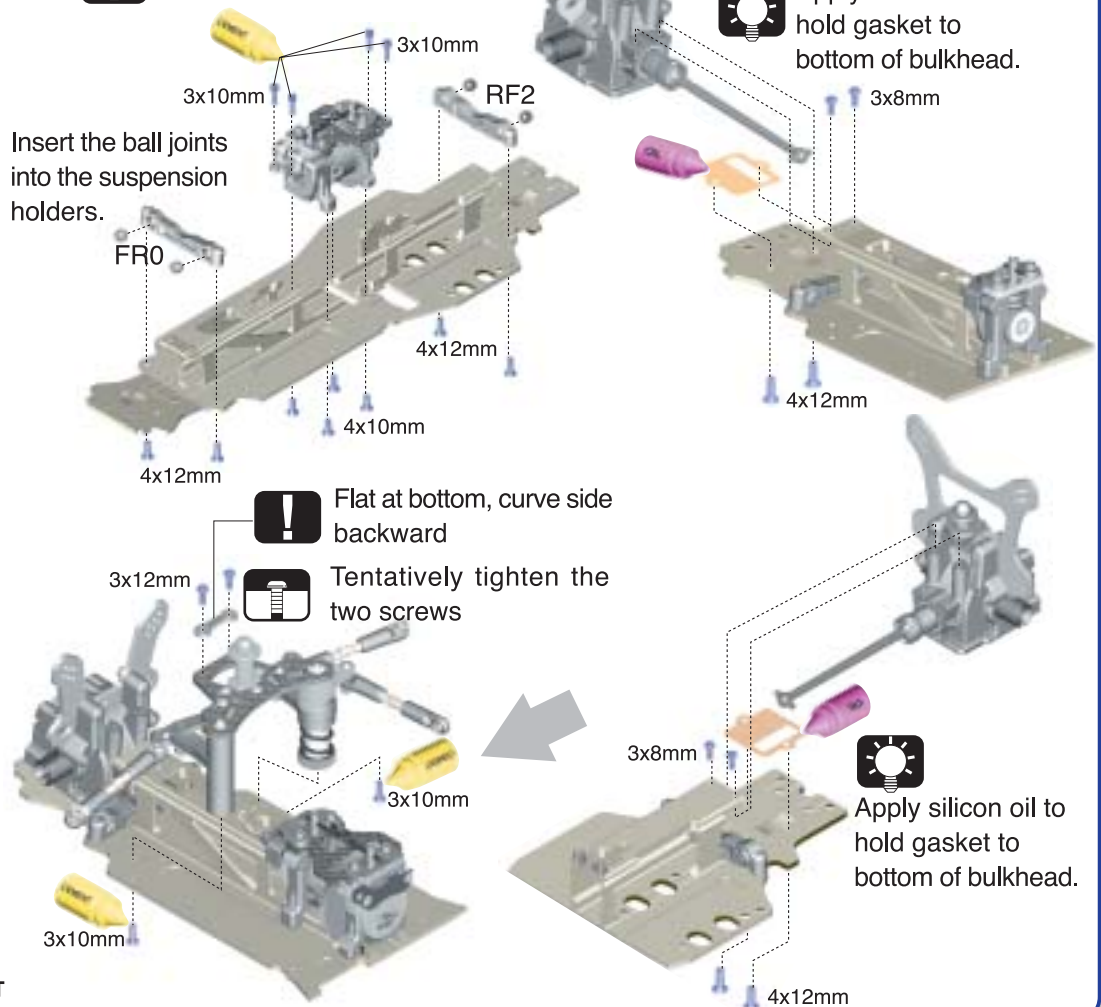

6

FRONT SUSPENSION

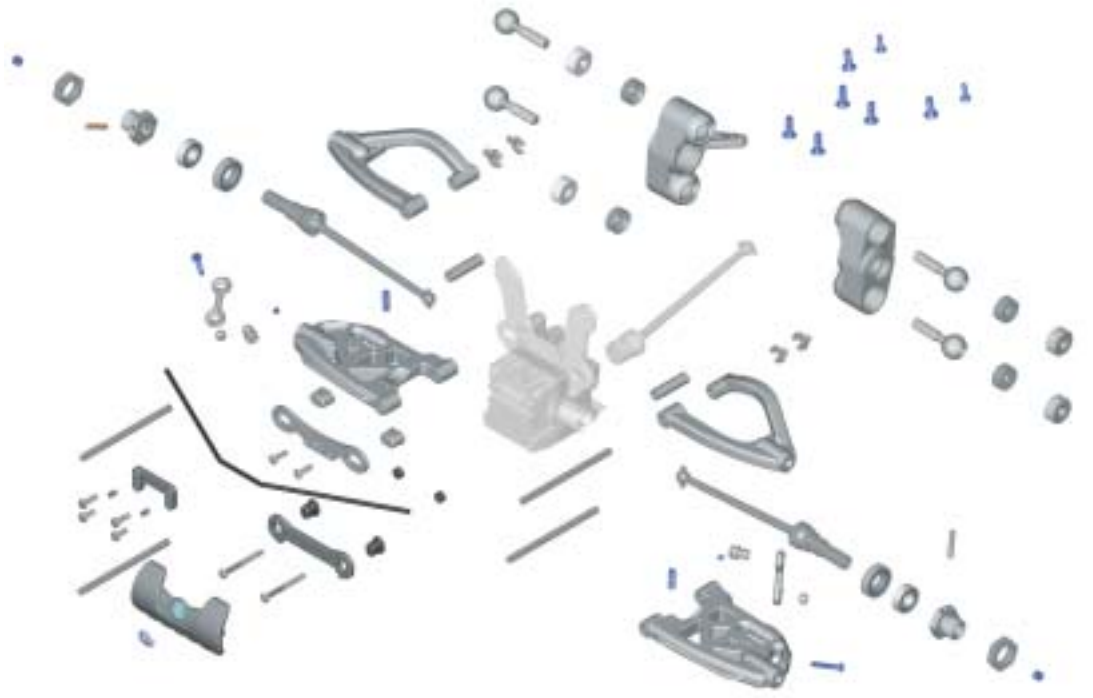

6.1

Roll Pin, $\phi 3 \times 17 \text{mm}$

M5x4mm Set Screw

$\phi 8 \times 16 \text{mm}$ Bearing

$\phi 9 \times 9 \text{mm}$ Bearing

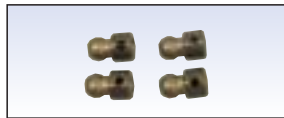
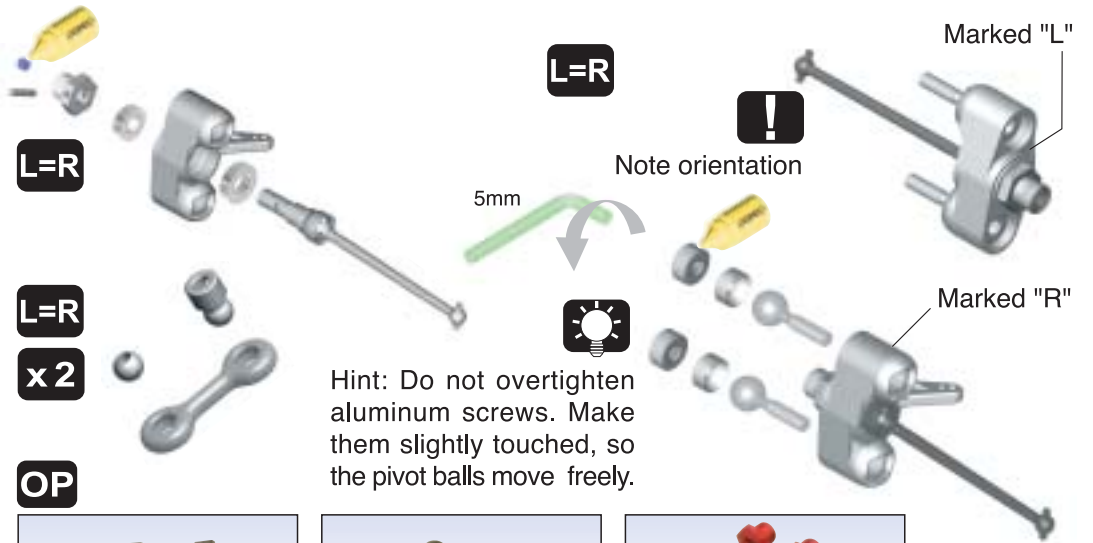

PD1860 HARD SWAY BAR BALL, S3

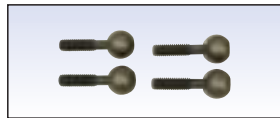

PD1863 LITE PIVOT BALL, S3 OPT

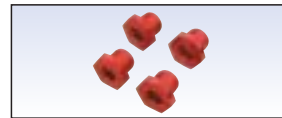

PD1864 LITE HEX WHL ADAPTER, S3 OPT

6.2

M4x12mm Set Screw

M3x16mm Button Head Hex Screw

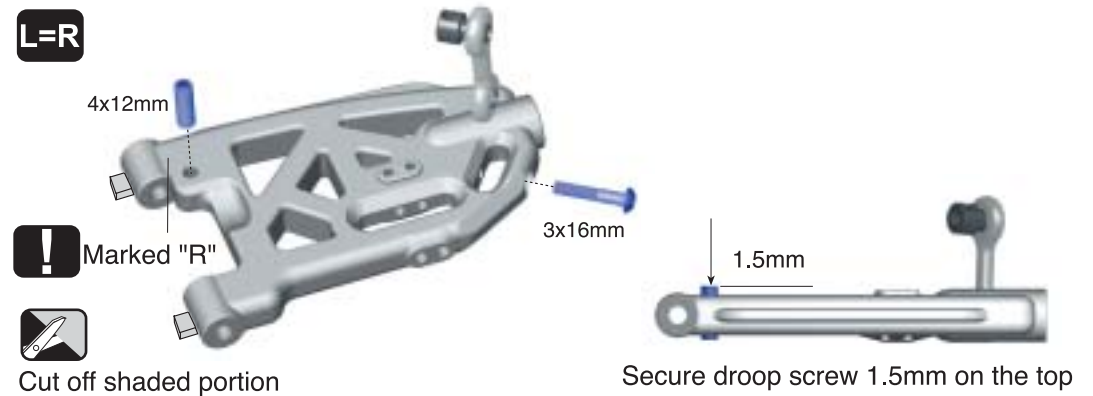

6

6.3

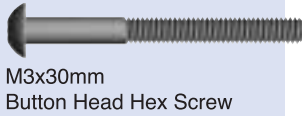

M3x30mm
Button Head Hex Screw

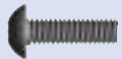

M3x10mm
Button Head Hex Screw

6.4



M3x3mm
Set Screw



M3x5mm
Set Screw

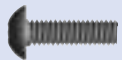

M3x10mm
Button Head Hex Screw

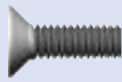

M4x12mm
Flat Head Hex Screw

6.5

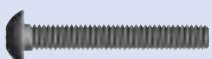

M3x20mm
Button Head Hex Screw



Lock Nut, M3

1-2-3

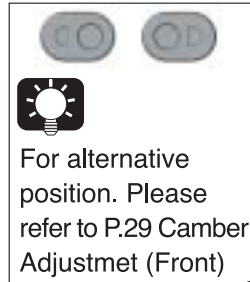

Marked "R"

2

3

3x10mm

3x30mm

!

Marked "L"

1

Check out non-binding movement



OP

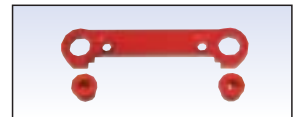

PD1847 ALUM FR PLATE FR TRANS, FF-1, S3 OPT

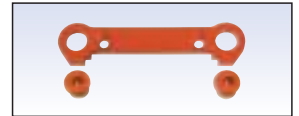

PD1848 ALUM FR PLATE FR TRANS, FF0, S3 OPT

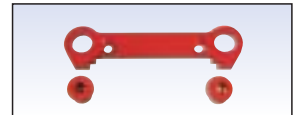

PD1849 ALUM FR PLATE FR TRANS, FF+1, S3 OPT

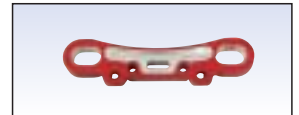

PD1855 A7075 UPPER ARM PLATE, S3 OPT

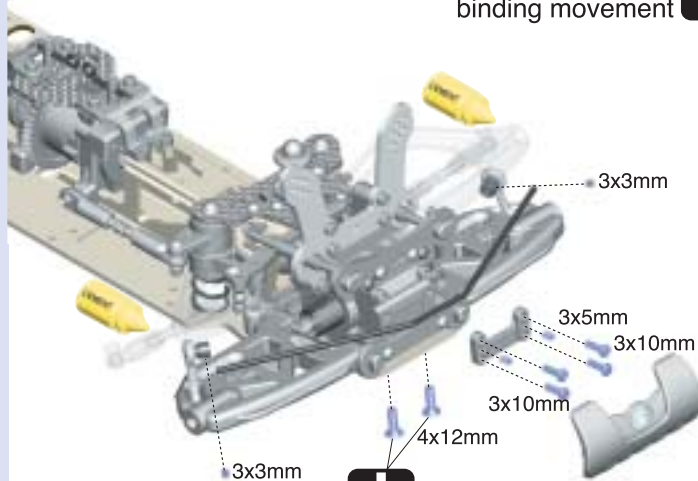

OP

!

From F bag

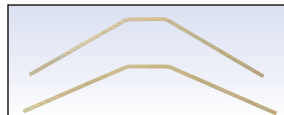

PD1866 SWAY BAR, GOLD 3mm, S3

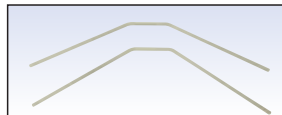

PD1867 SWAY BAR, SILVER 2.5mm, S3

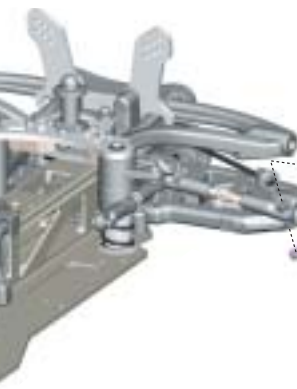

L=R

3x20mm

Marked "R"

2.5mm

L=R

7mm

!

7.5mm

Initial setting of track width



Please refer to setup sheet for Camber Angle Track Width.

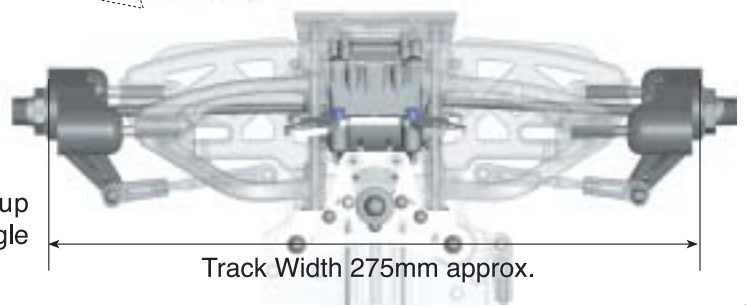

Track Width 275mm approx.

7

REAR SUSPENSION

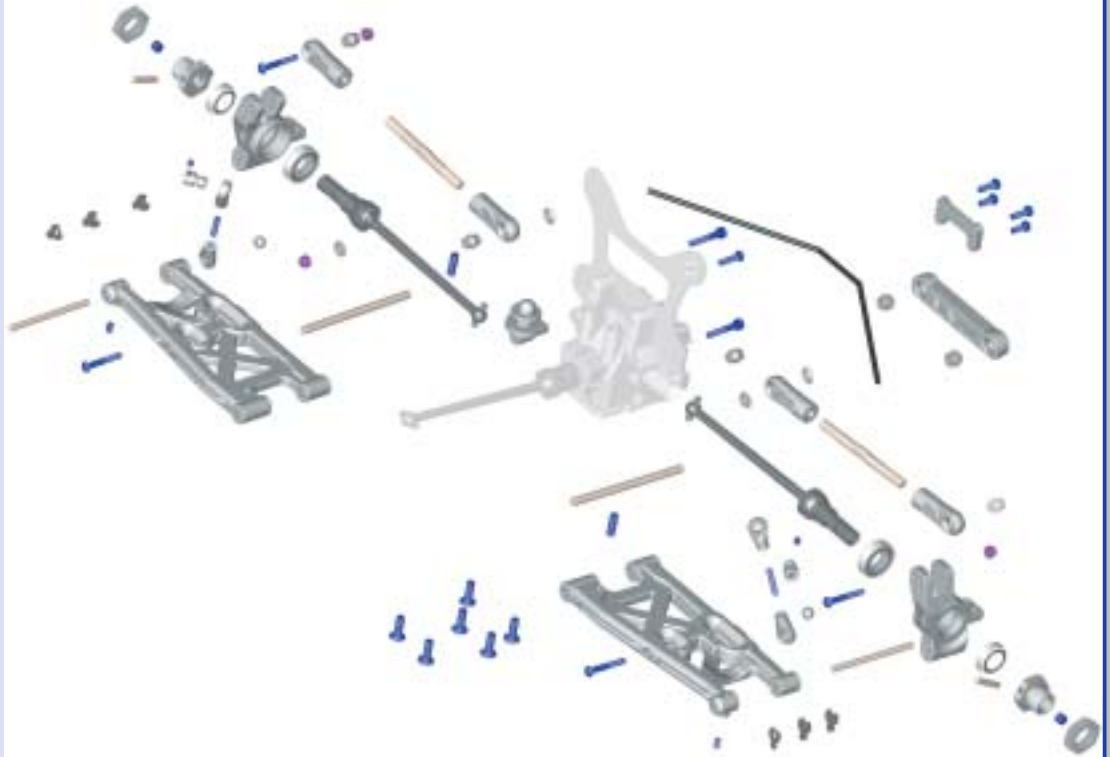

7.1

M3x12mm
Set Screw

Roll Pin, ø3x17mm



M5x4mm Set Screw

ø8x16mm Bearing

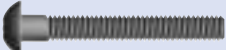

ø9x9mm Bearing

7.2



M4x12mm
Set Screw

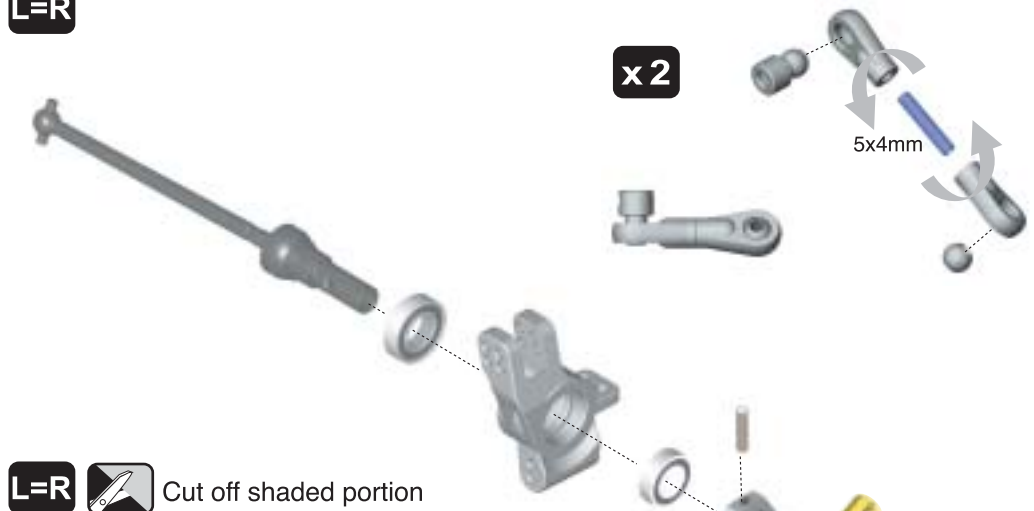

M3x22mm
Button Head Hex Screw

L=R

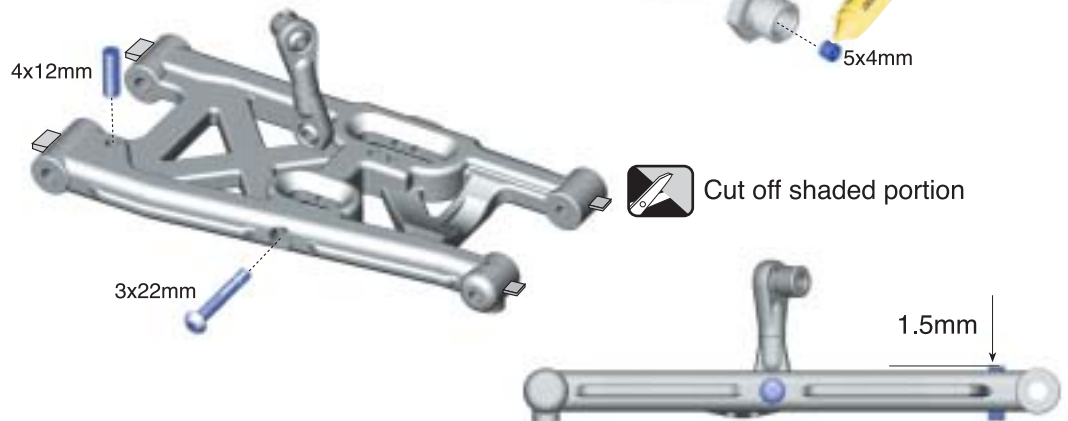

L=R

 Cut off shaded portion



Secure drop screw 1.5mm on the top

7

7.3

M3x5mm
Set Screw

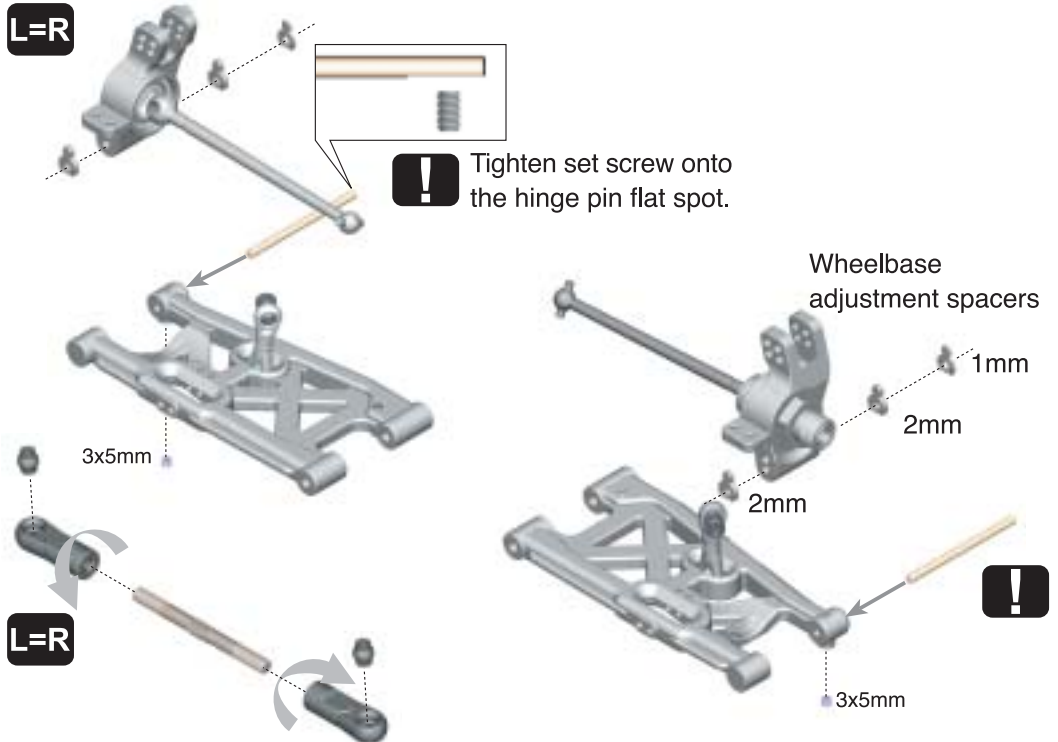

7.4



7.5

M4x12mm
Flat Head Hex Screw

OP



PD1853 A7075 RR PLATE RR TRANS, RR+2, S3 OPT



PD1854 A7075 RR PLATE RR TRANS, RR+3, S3 OPT

7.6



M3x18mm
Socket Head Hex Screw

Lock Nut, M3

M3x22mm
Button Head Hex Screw

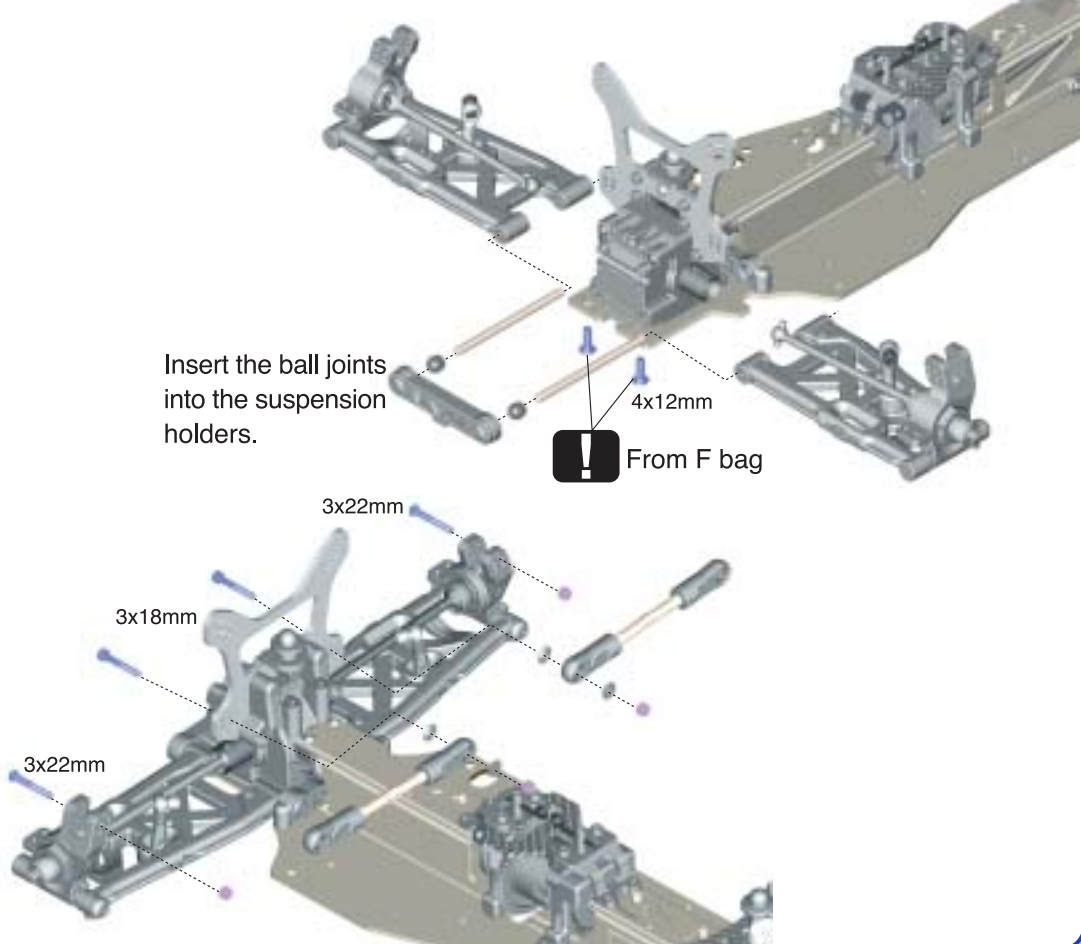

Insert the ball joints into the suspension holders.





7

L=R

7.7

7.8

-  M3x3mm Set Screw
-  M3x5mm Set Screw
-  M3x10mm Button Head Hex Screw

OP

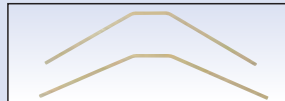

PD1866 SWAY BAR, GOLD 3mm, S3

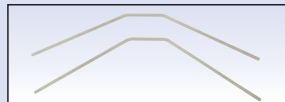

PD1867 SWAY BAR, SILVER 2.5mm, S3

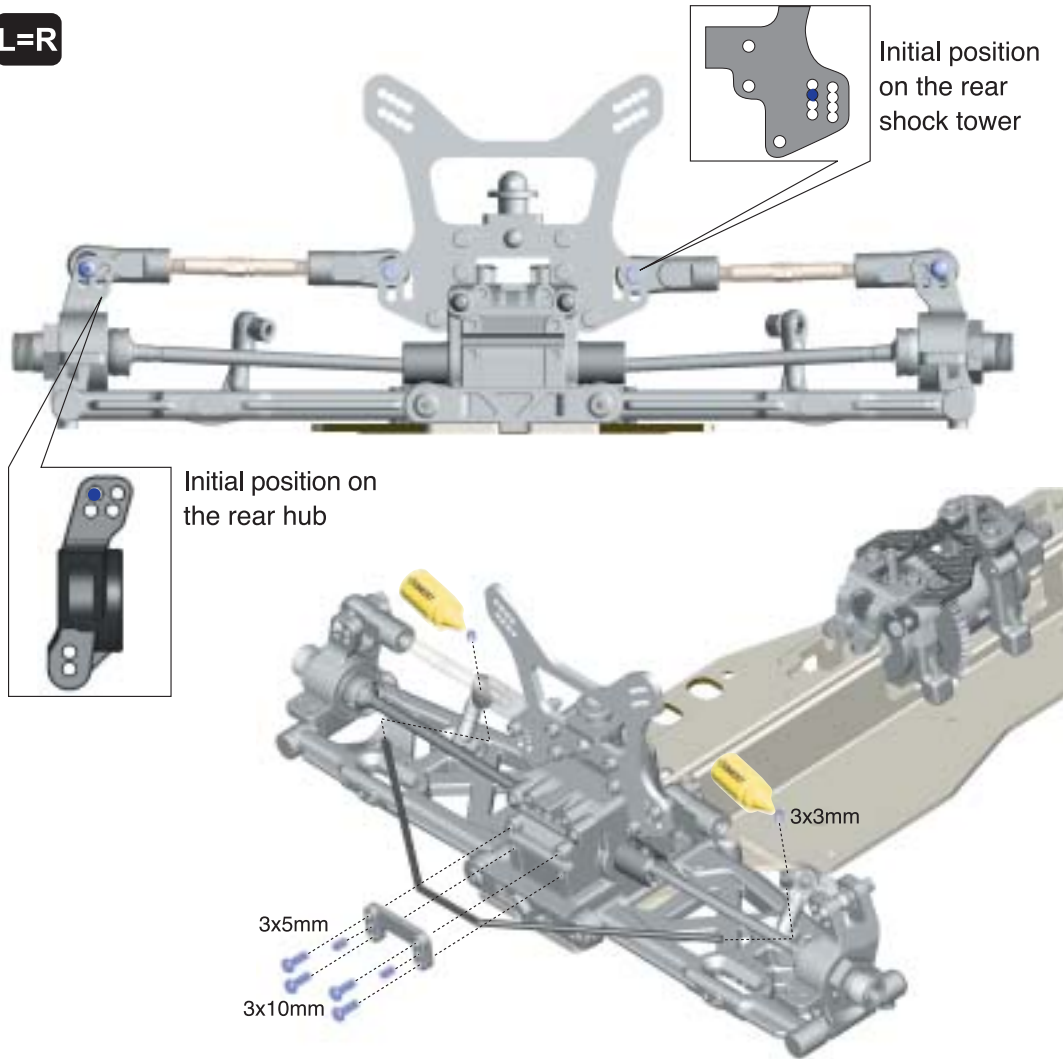

8

SIDE GUARD



 Lock Nut, M3

 M3x8mm Flat Head Hex Screw

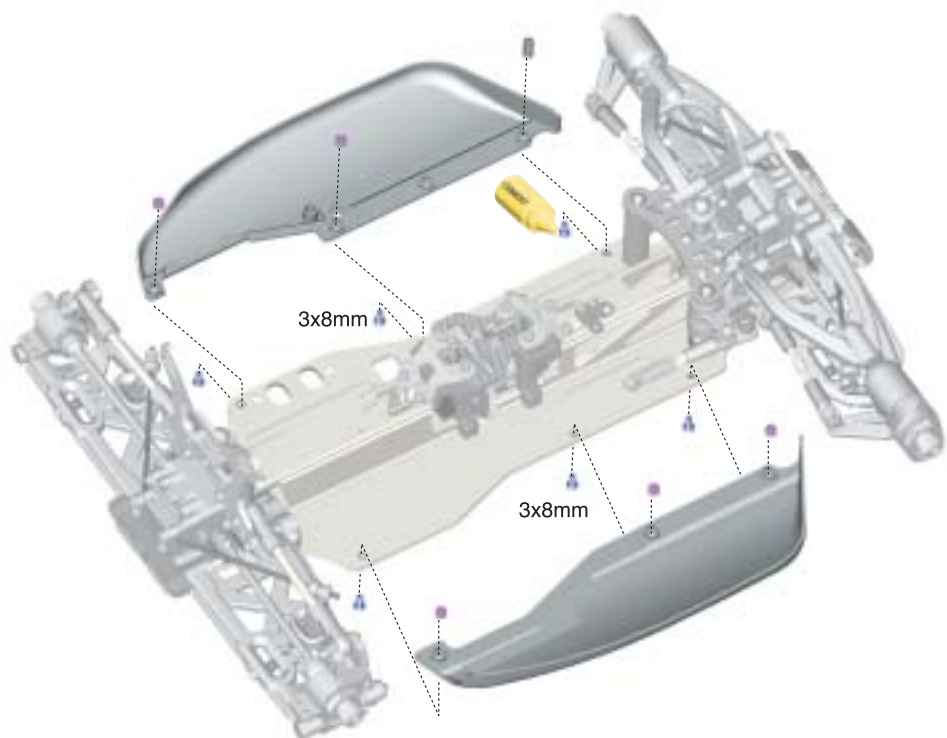

9

RADIO BOX & FUEL TANK

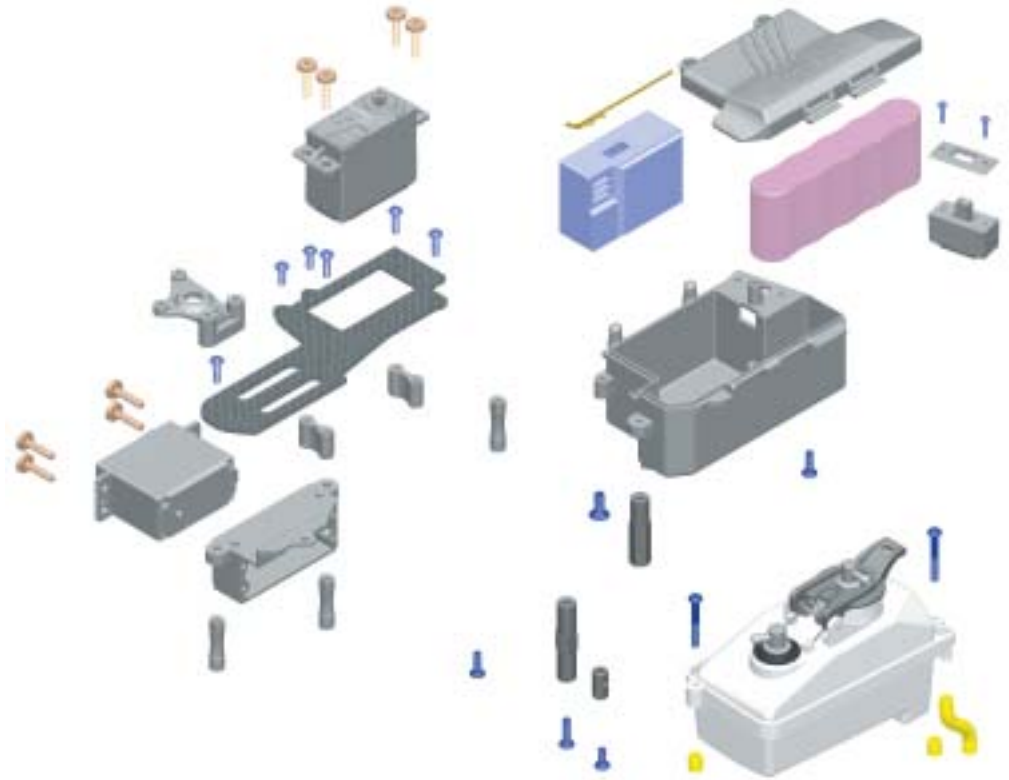

9.1

M3x8mm Button Head Hex Screw

M3x10mm Button Head Hex Screw

M3x14mm Flat Head Socket Screw

OP

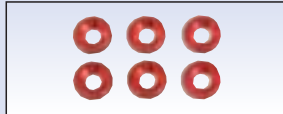

AD2523-R ANODIZED WASHER, OPT



PD0680 CT MACHINE SCREW M3x14mm

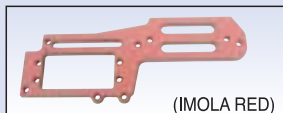

PD1842-R CARBON SERVO TRAY(R), S3 OPT

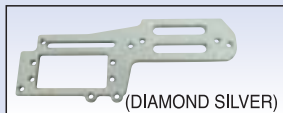

PD1842-S CARBON SERVO TRAY(S), S3 OPT

Apply few drops of CA glue around the profile edge of the carbon plate for added strength.

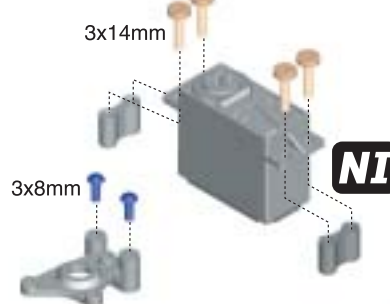

Hint: You can use servo grommets to protect your servo (Not Included)

NI Battery pack & Receiver not included

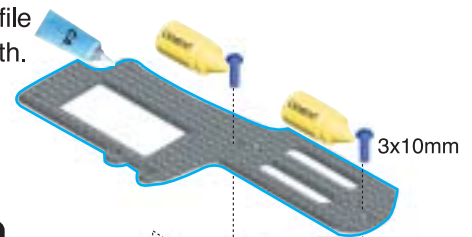

NI Servos not included

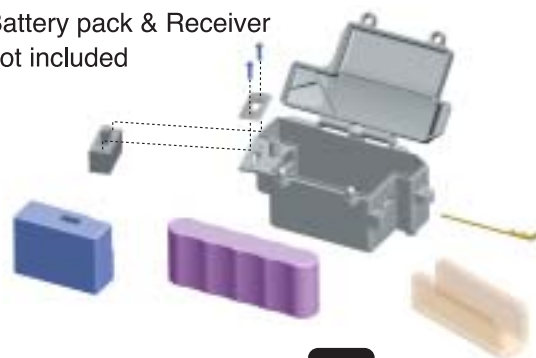

NI Foam not included

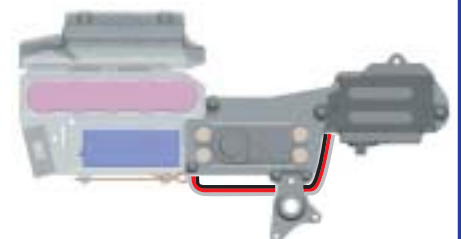

Route servo lead as shown
Route the receiver wire through the mounting hole and the antenna tube.

Hint: Use foam to cushion the battery pack and receiver for vibration protection.

9

9.3



M3x10mm
Button Head Hex Screw



M3x10mm
Flat Head Hex Screw

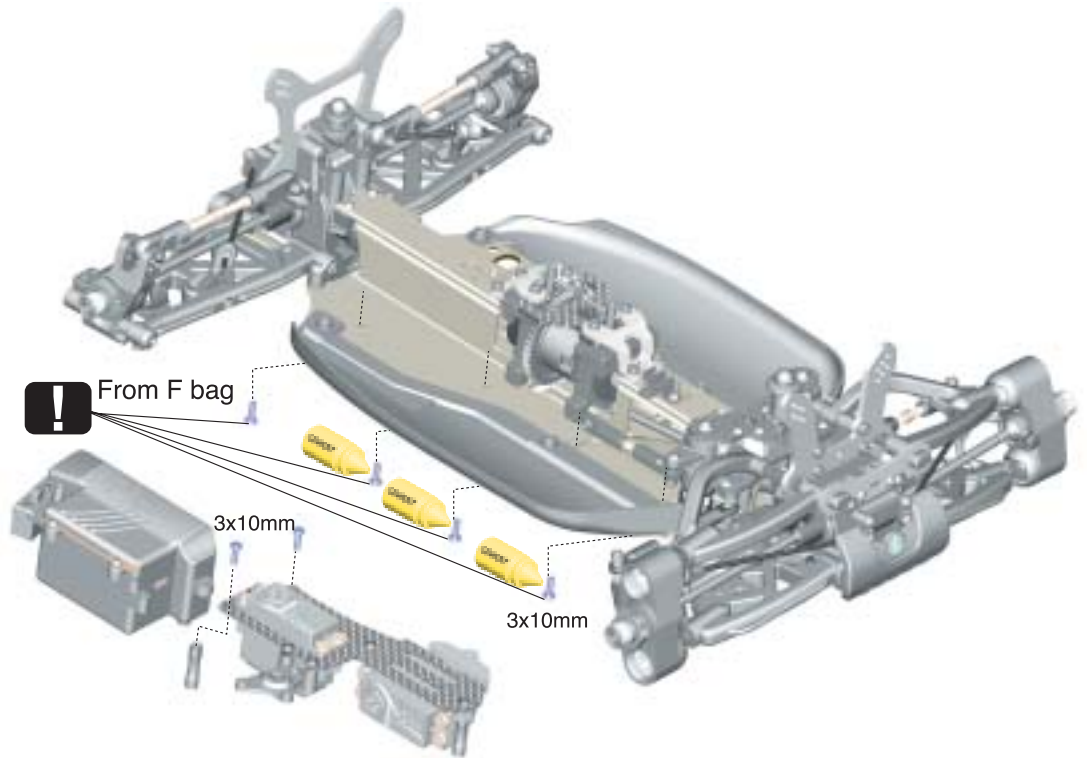

9.4



M3x12mm
Flat Head Hex Screw



M3x22mm
Button Head Hex Screw

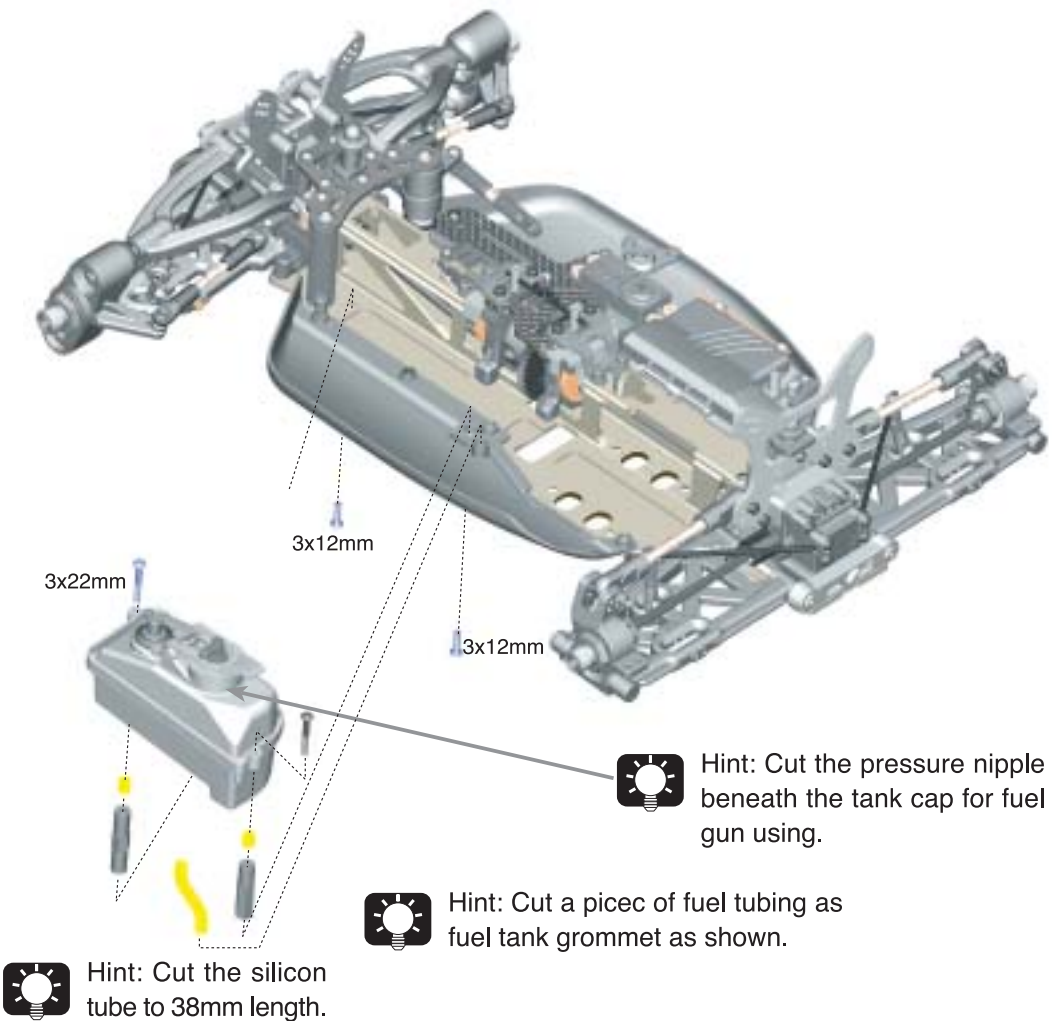

10

ENGINE MOUNT & CLUTCH SET

K
bag



! Note the orientation of the clutch shoes.

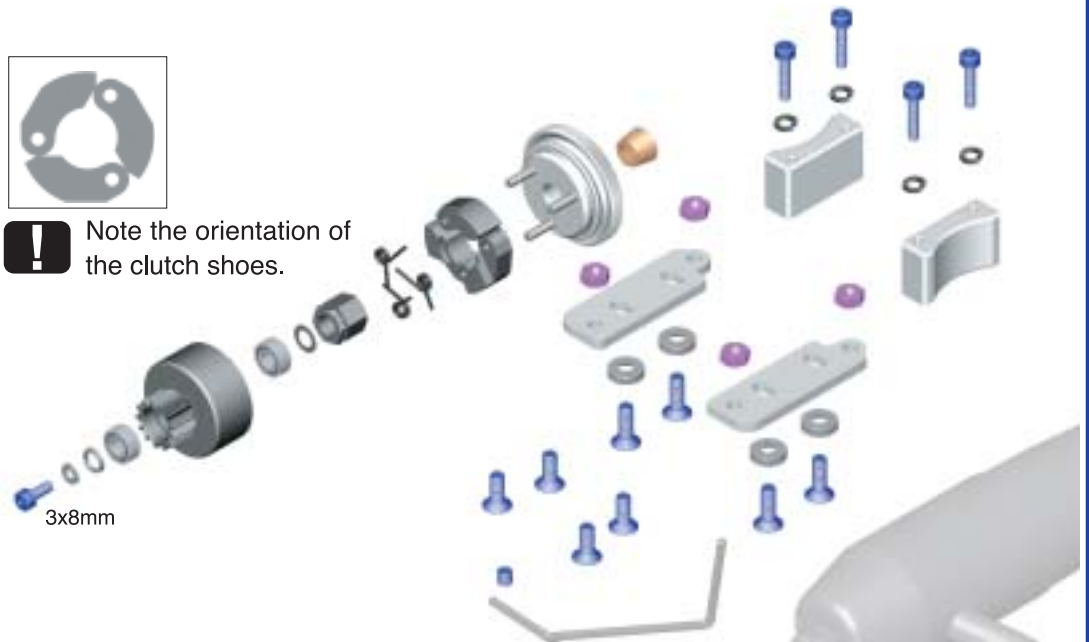

M3x8mm
Socket Head Hex Screw

3x8mm

10.1



M4x10mm
Flat Head Hex Screw



Lock Nut, M3

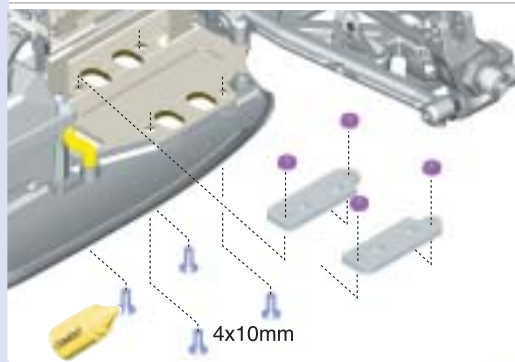

Hint: For easily adjust the gear mesh, the lock nuts are not necessary to install only when the fixing screws get loose.

10.2



M4x12mm
Flat Head Hex Screw



M3x14mm
Socket Head Hex Screw



ø3mm
Lock Washer



Insert a sheet of paper to adjust proper gear mesh.

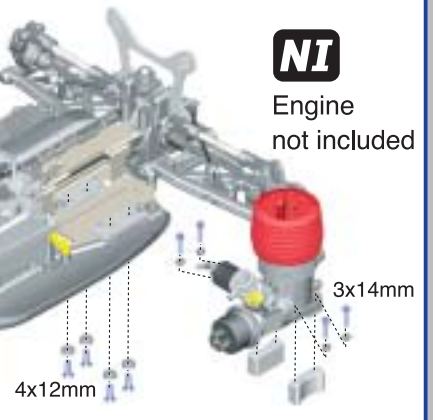

NI

Engine not included

10.3



M4x4mm Set Screw

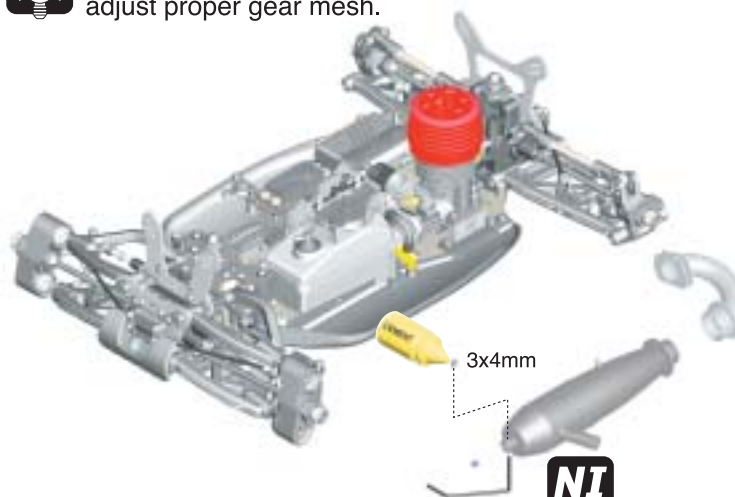

NI

Muffler and manifold not included

OP



PD1859 LITE ENGINE MOUNT

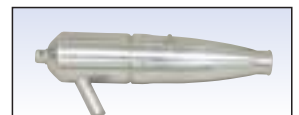

PD1796 MUFFLER, (L)



PD1797 MUFFLER, (S)



PD1798 MANIFOLD

11

THROTTLE AND BRAKE LINKAGE

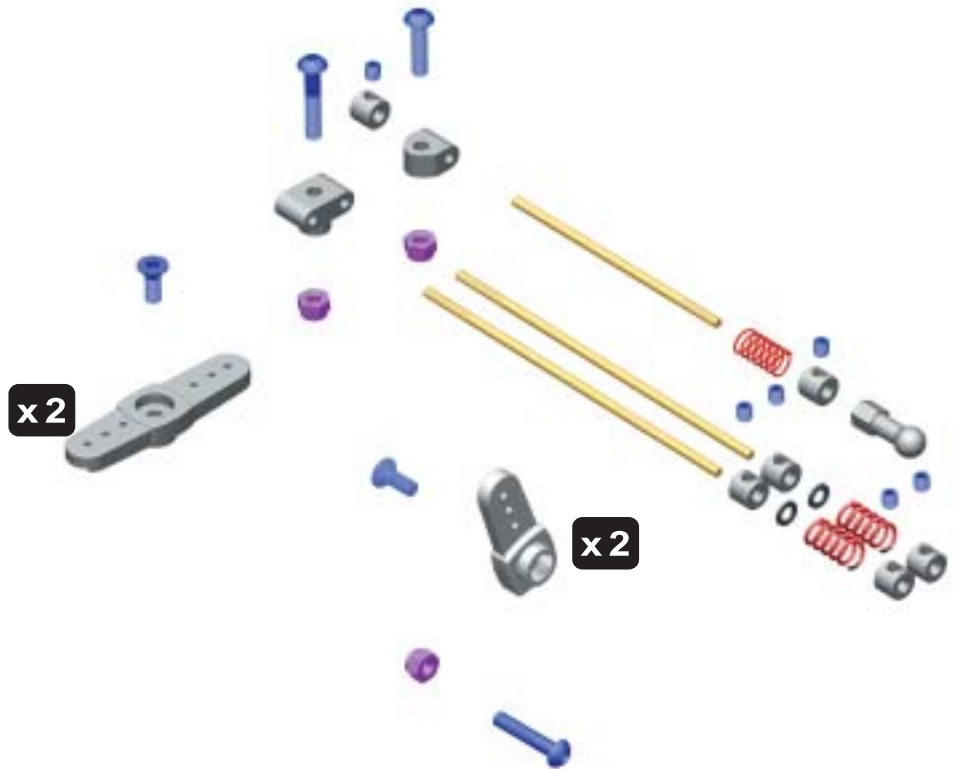

11.1

 M3x3mm Set Screw

 Flat Washer, $\varnothing 2.6$

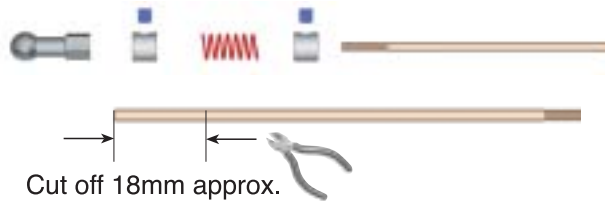

Cut the attached throttle rod in the bag (Approx. 18mm) to avoid interfering.

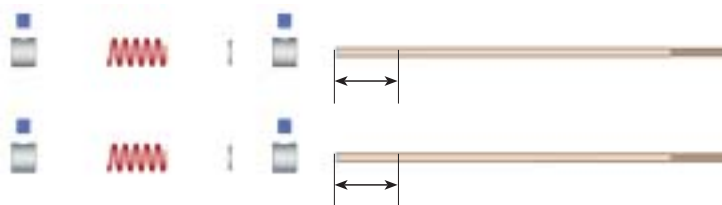

Cut off excess of the end of rod for not hitting the tank.

11.2

 M3x8mm Button Head Hex Screw

 M3x12mm Button Head Hex Screw

 M3x16mm Button Head Hex Screw

 Lock Nut, M3

 Install appropriate servo horn according to your servo.



Hint: Use the collars to adjust the brake rod.

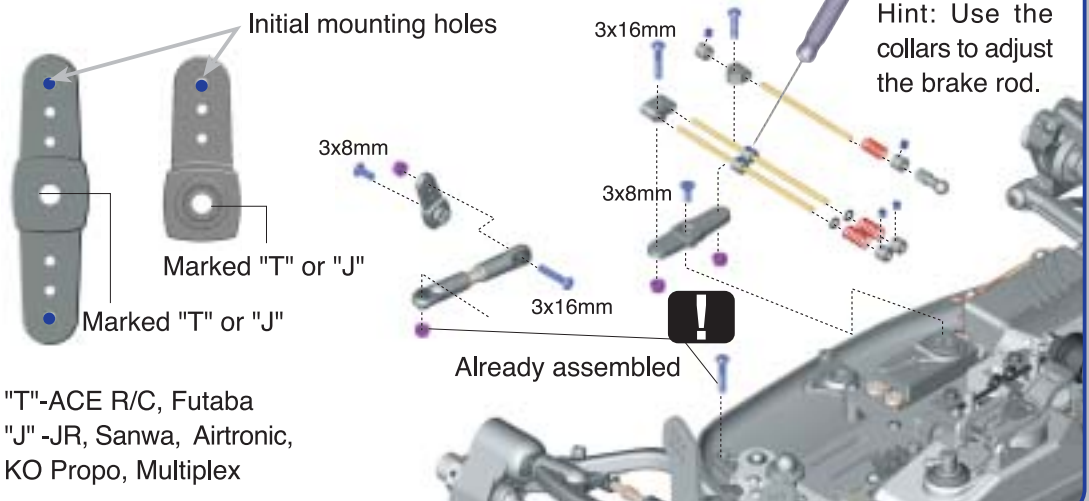

11

11.3 Throttle linkage adjustment

1. Neutral

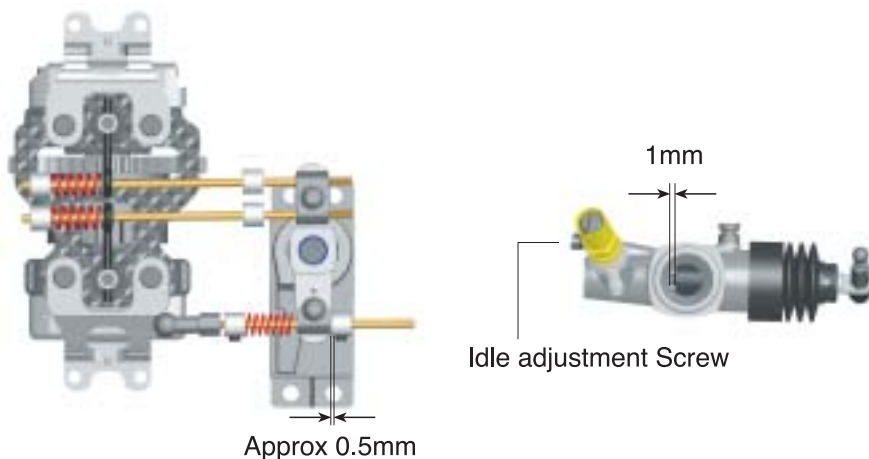

2. High throttle

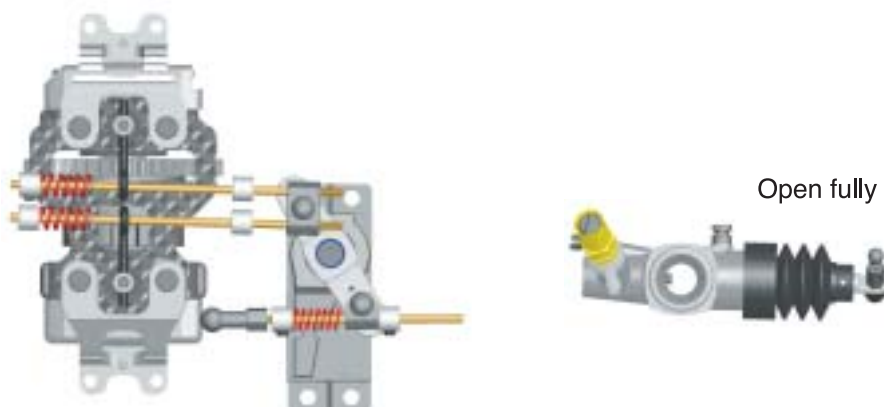

3. Brake

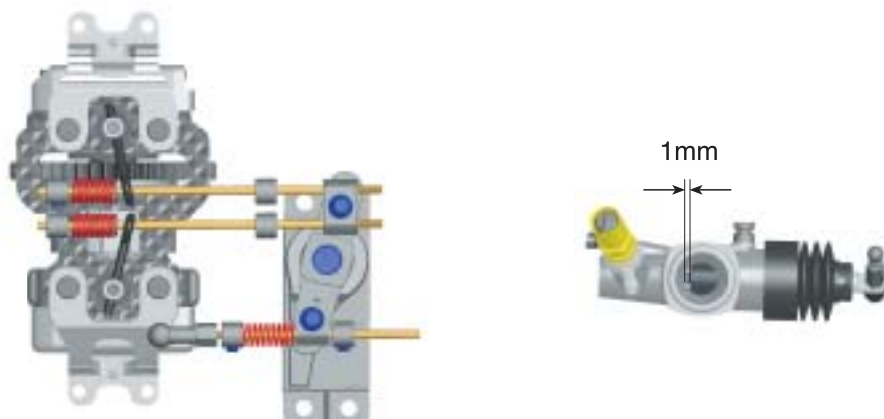

Neutral

- Turn on the transmitter and receiver and set engine control servo trim to the neutral position.
- Adjust the idle adjustment screw on the carburetor to open approx. 1mm.
- Adjust both throttle linkage and brake linkage accordingly.
- * Do not adjust engine while it is running.

High throttle

- Adjust the servo-horn mounting position for the carburetor to open fully.
- Change the pivot mounting position on the servo horn in case the carburetor is not open fully or if it is opening excessively.
- Or if ATV/ EPA functions are available on the transmitter, adjust the throttle high end point.

Brake

- Adjust the collars so the brakes work smoothly.
- If the brake applies too much or not enough, adjust the adjustment collars accordingly.
- Or if available on the transmitter, adjust the brake endpoint.

12

AIR FILTER

M
bag

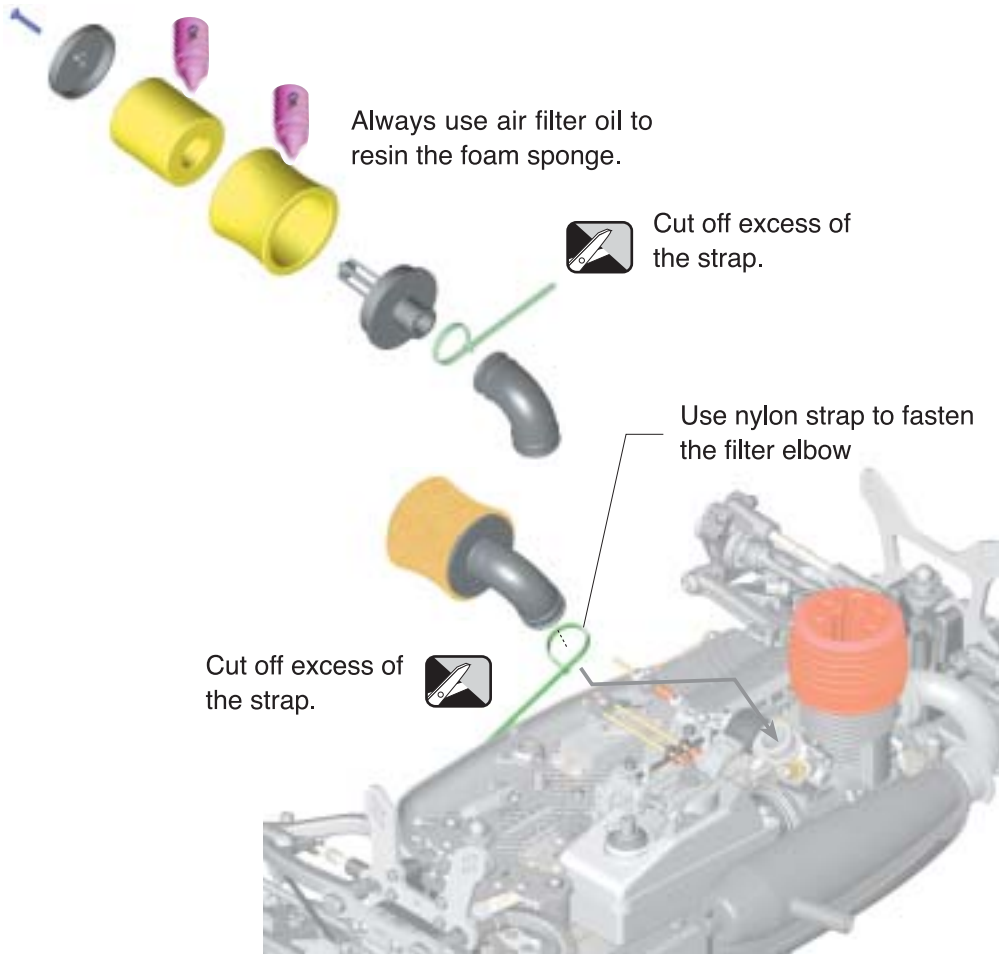

Always use air filter oil to resin the foam sponge.



Cut off excess of the strap.

Use nylon strap to fasten the filter elbow

Cut off excess of the strap.



Hint: Apply CA glue around the base of the pressure fitting to prevent fuel leaking.

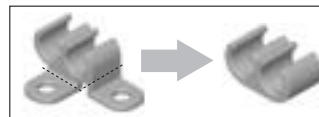

Cut off shaded portion if necessary.



From J BAG

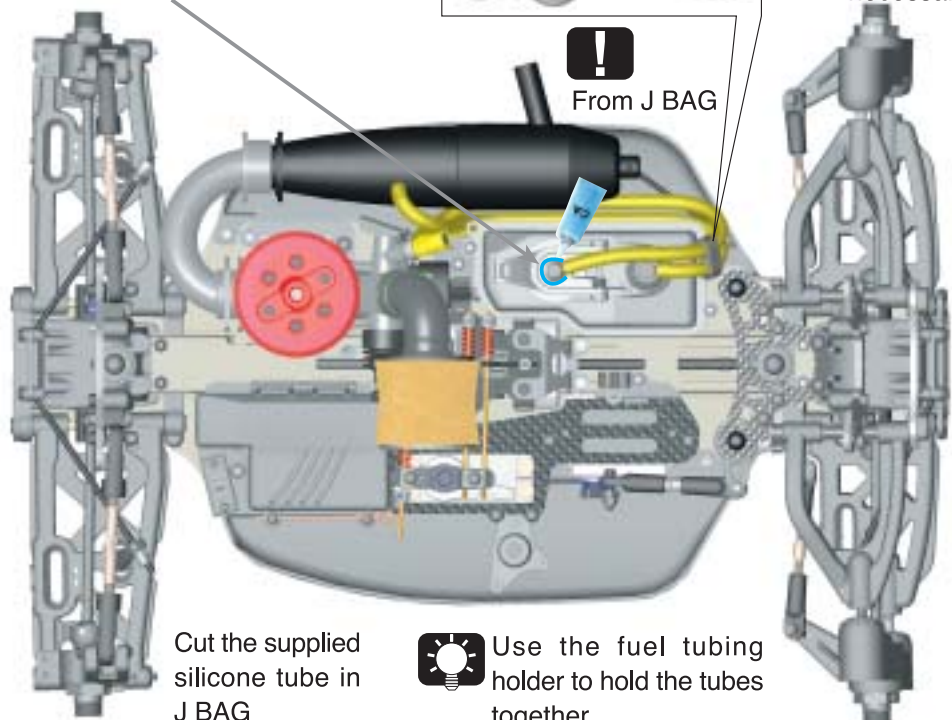

Cut the supplied silicone tube in J BAG



Use the fuel tubing holder to hold the tubes together.

13

SHOCK ABSORBERS

N
bag

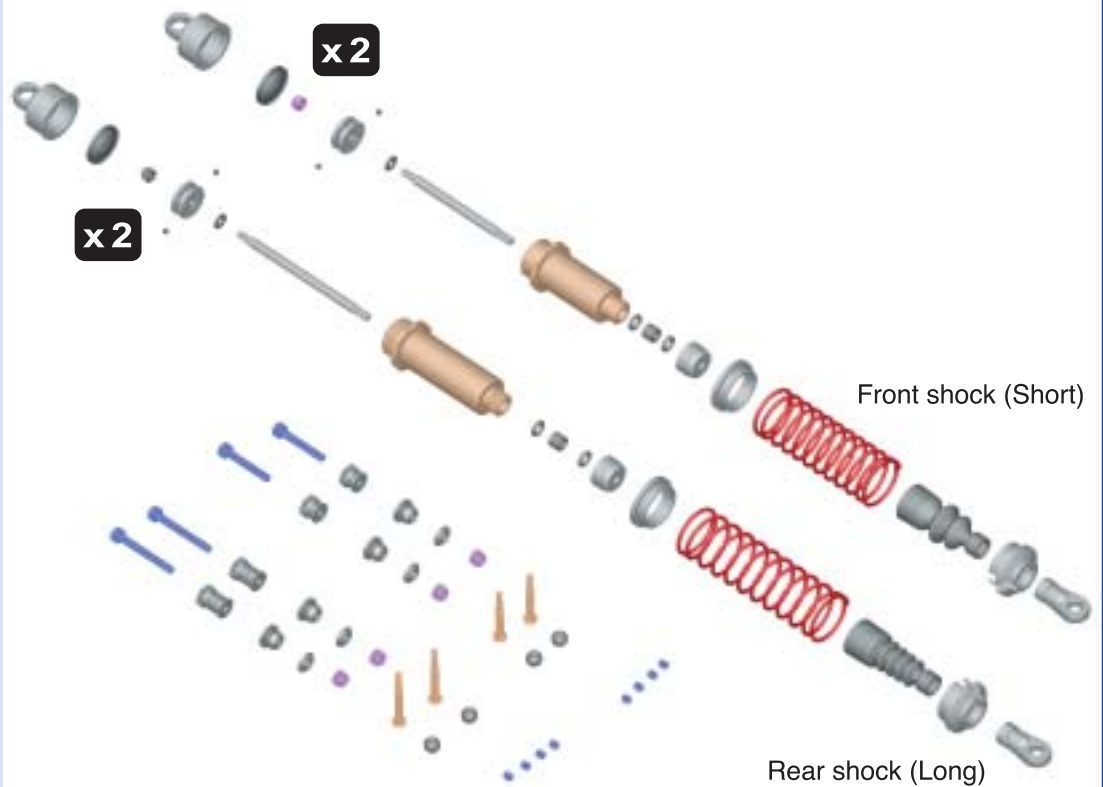

13.1

Lock Nut, M2.6

Place a few drop of silicon oil on the tip of the shaft before inserting through the shock body to prevent shaft thread from damaging the o-ring seals.



HINT: There are two attached steel balls installed inside the Anti-Bumping piston for variable shock damping .

Ball Numbers	Damping Characteristics
0	Softer damping at rebound. Increase traction
1	↑↓ Harder damping at rebound. Decrease traction
2	

Recommended

Shock Silicon Oil	
Front 40wt	Rear 35wt

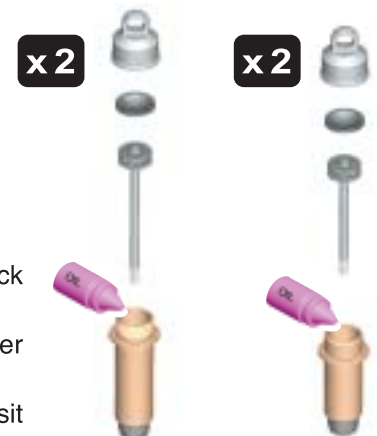
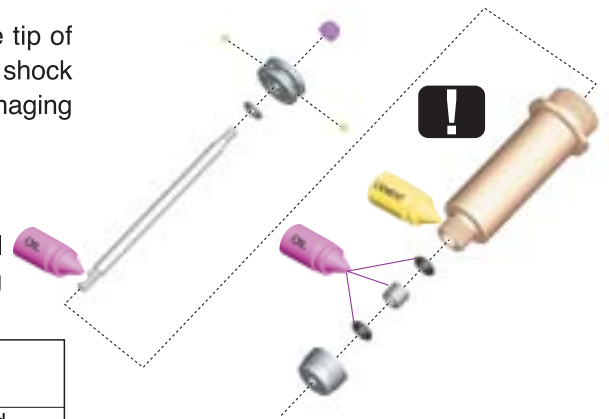

13.2

1. Use recommended grade of silicon oil and fill the shock bodies.
2. Move the shaft / piston up & down gently (But never broken oil top surface)
3. To release any trapped air inside the silicon oil, let it sit for a few minutes for all the air bubbles to be release.

13

13.2

OP



PD1994 ALUM SHOCK SPRING RETAINER, S3 OPT

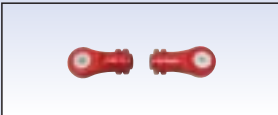

PD1995 ALUM SHOCK BOTTOM, S3

4. Fill the shock bodies all the way up with silicon oil. Place the diaphragm in the shock cap and quickly screw the cap into place.

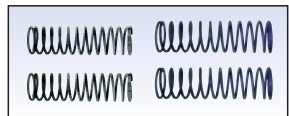

PD1996 FR SHOCK SPRING SET, 1.4mm(BLUE3.2lb) 1.6mm(BLACK5.2lb), S3

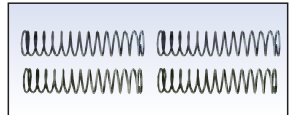

PD1997 RR SHOCK SPRING SET, 1.4mm(BLUE2.7lb) 1.6mm(BLACK4.5lb), S3

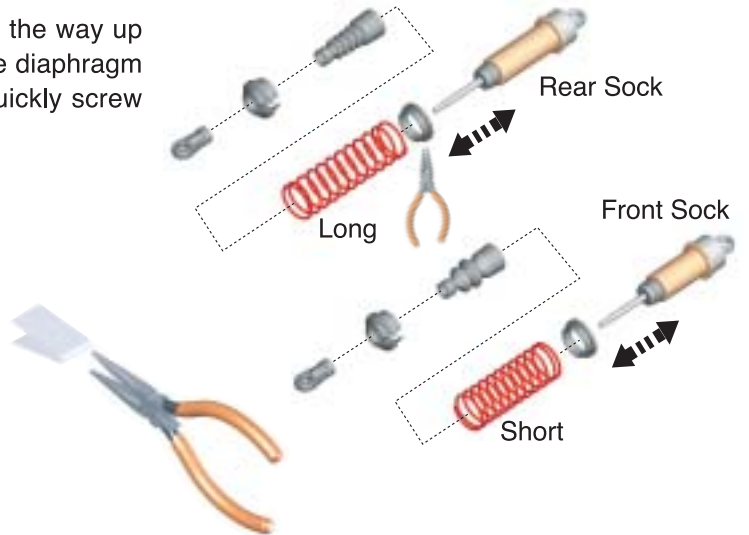

Hint: Use a piece of masking tape to protect the shock shaft.

13.3



M3x25mm Socket Head Hex Screw



Lock Nut, M3



M3x3mm Set Screw



Hinge Pin (short)

13.4



M3x20mm Socket Head Hex Screw



Lock Nut, M3



M3x3mm Set Screw



Hinge Pin (long)

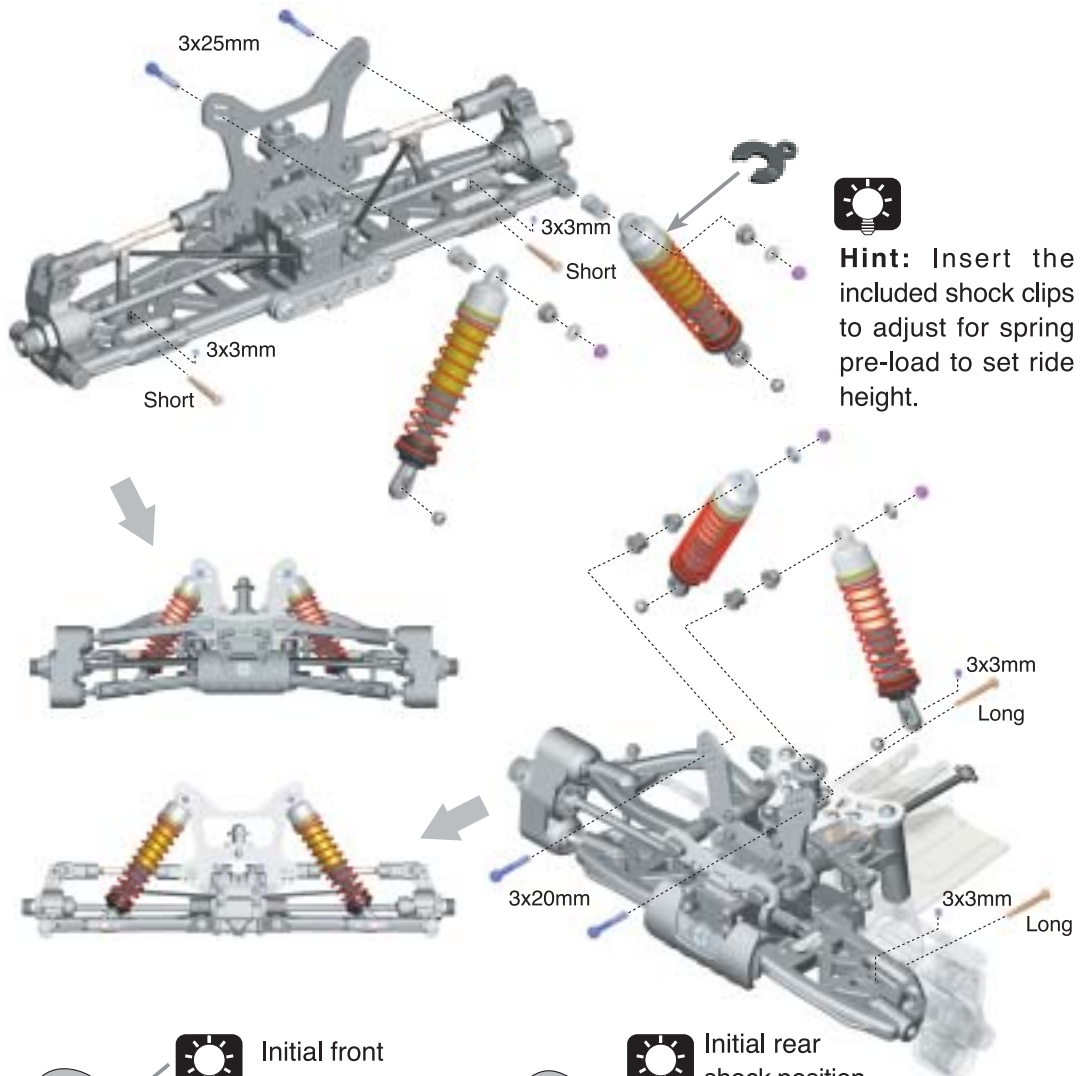

Hint: Insert the included shock clips to adjust for spring pre-load to set ride height.

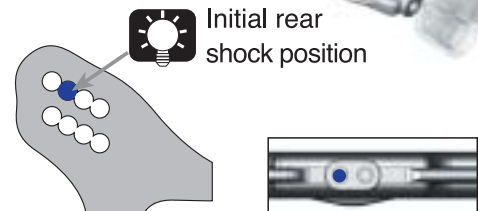
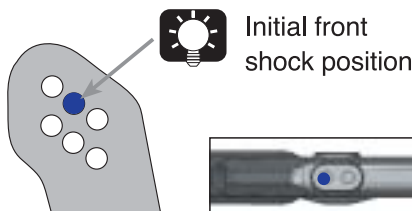

14

REAR WING



14.1



M3x10mm
Button Head Hex Screw



ø3xø8
Special Washer

OP

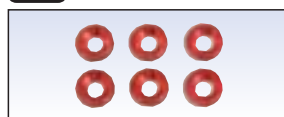

AD2523-R ANODIZED WASHER, OPT



PD0680 CT MACHINE SCREW M3x14mm
For AD2523-R

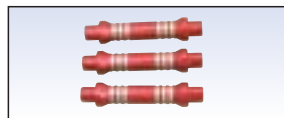

PD1862 WING POST, S3 OPT

14.2



M3x10mm
Button Head Hex Screw



M3x14mm
Button Head Hex Screw



ø3xø8
Special Washer



M3x18mm
Socket Head Hex Screw

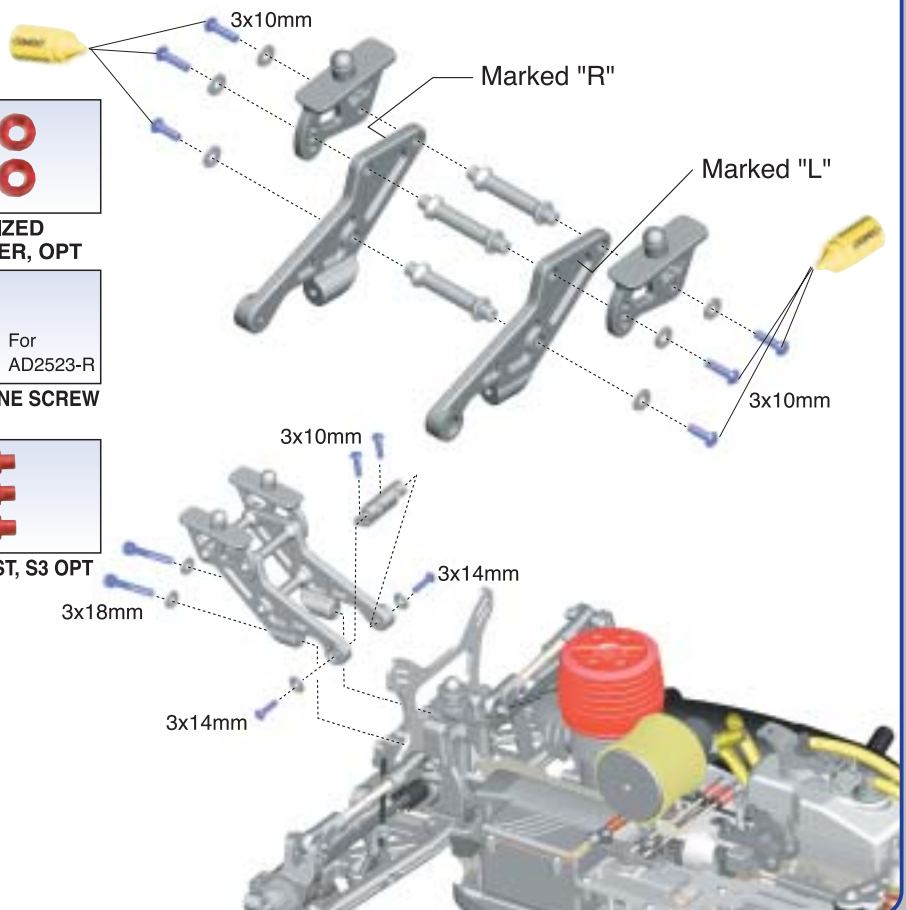

15

WHEELS AND TIRES (Not Included)

P
bag

15.1

OP



PD1865 LITE SELF-LOCK WHL
HEX NUT, S3 OPT

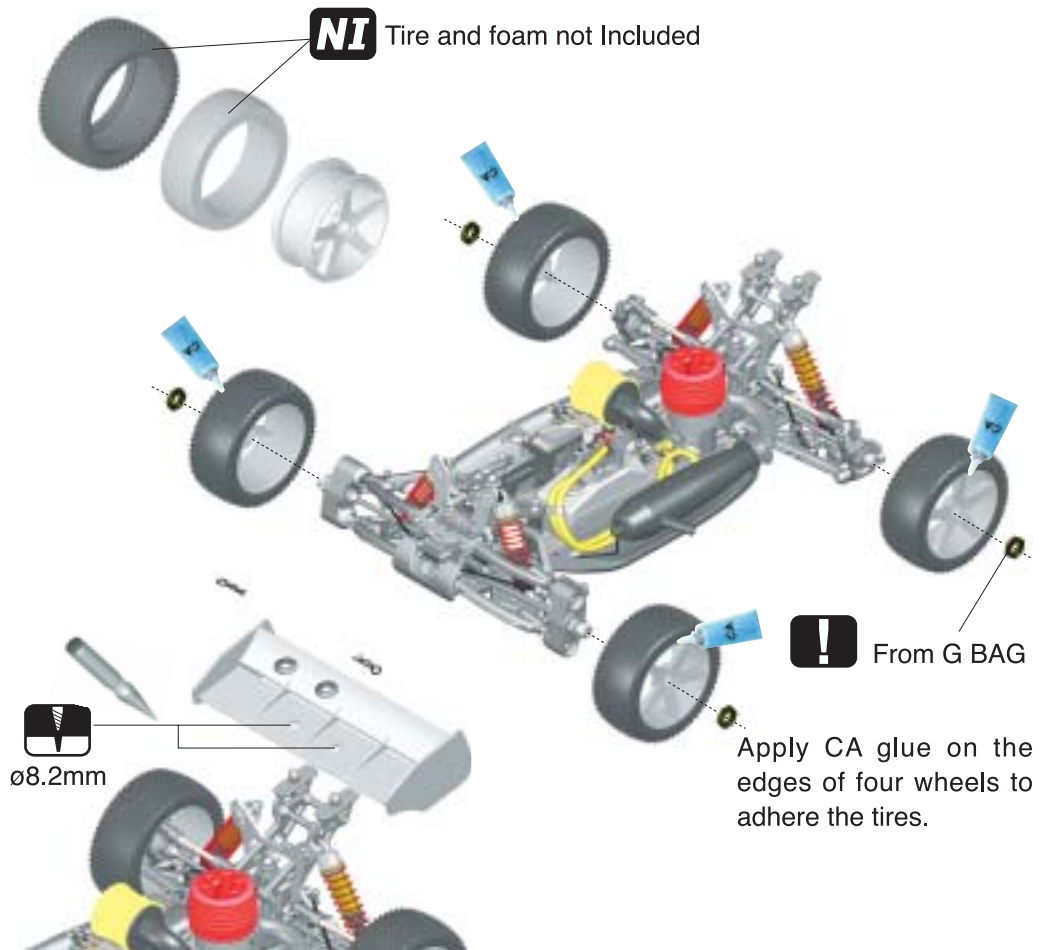

16

BODY

Q
bag

R
bag

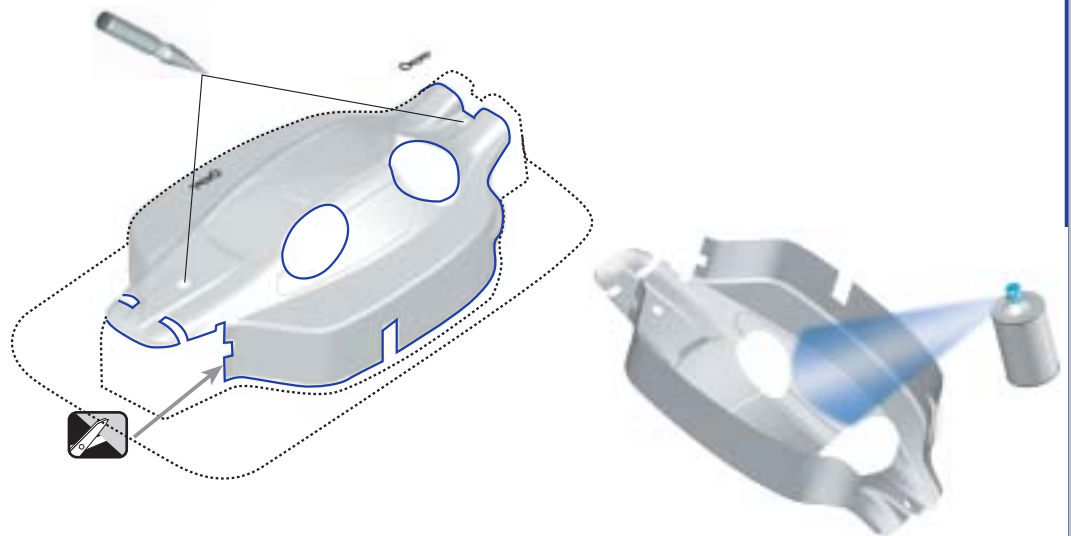

1. Use special round scissors or hobby knife to cut out the body around the lines.
2. Wash the inside of body using soap and water to remove residual oil or other goop remains.
3. Mask the windows and then paint the inside of body with special lexan paint.
4. Wait for the paint dry, and then peel off the external protective films.

SET UP

Toe Adjustment (Front)

1. Toe Adjustment (Front) Adjust the front toe angle by tuning the length of the left and right steering rod.

Rod length	Steering Characteristics
Tuning longer More front toe-in	<ul style="list-style-type: none"> Increases straight-line stability Makes the steering response milder
Tuning shorter More front toe-out	<ul style="list-style-type: none"> Decreases straight-line stability Makes the steering response quicker



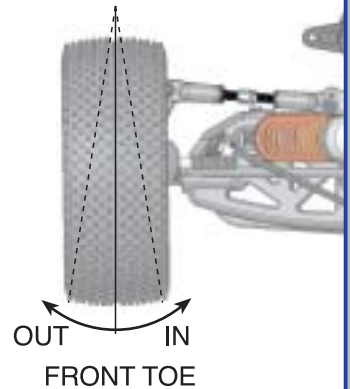

Note: Ensure you adjust either the length of right and left tie rod the same.

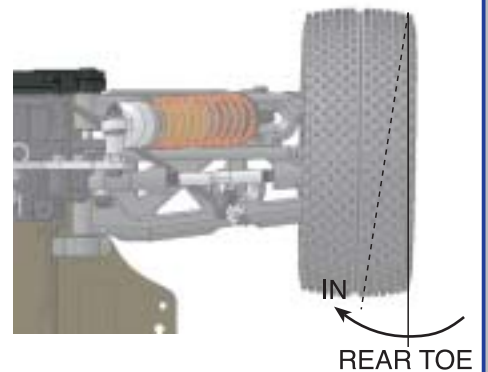

Toe Adjustment (Rear)

2. Toe Adjustment (Rear) Adjust the rear toe angle by changing the various toe blocks behind the rear bulkhead. Take out the embedded plastic balls inside of the block length and re-insert to the new toe block. Replace the toe block. There are 4 different blocks that can be chosen for adjustments. Please refer to the table below.



Block No.	Rear toe-in angle	Steering Characteristics
RR1 	Less rear toe-in (Less grip)	Increases steering but decreases the stability on power when exiting corners.
RR 1.5 	↑ ↓	↑ ↓
RR 2 		
RR 3 	More rear toe-in (More grip)	Decreases steering but increases stability on power when exiting corners.

SET UP

Caster Adjustment (Front)

3. Caster Adjustment (Front) Adjust the caster angle by changing the plastic clips in the front upper hinge pin.

	Steering Characteristics
Clips behind upper arm More Caster (Note)	Sharper corner-in, slower corner-exit
Clips in the front of upper arm Less Caster	Slower corner-in, faster corner-exit

Hint: Using a needle nose pliers to install or reinstall the clips makes the adjustment much easier.



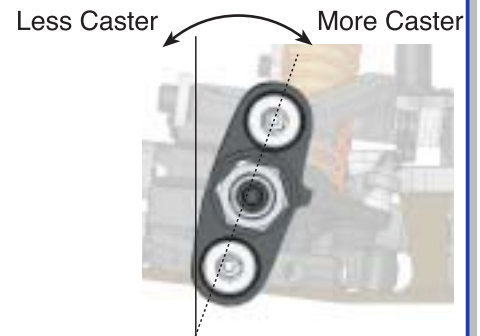
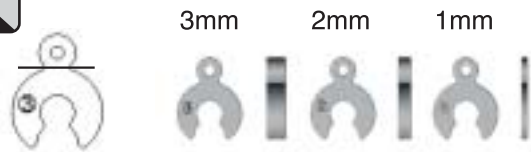
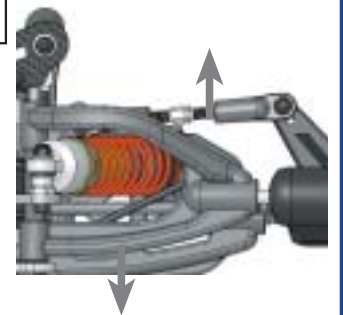

Note1: When putting the clips behind upper arms, cut the ear of the clips to avoid interfering with steering slider.

Note2: Ensure you make equal adjustments on both left and right sides of the car.



Front Anti-Squat Adjustment

4 Front Anti-Squat: The Front Anti-Squat angle can be adjusted using the different plastic eccentric bushings in the front suspension plate. Please refer to the table below.

Eccentric Bushing	Total	Characteristics
FF-1 	6°	 Decreases steering response. Good handling on bumpy tracks.
FF0 	7°	
FF1 	8°	

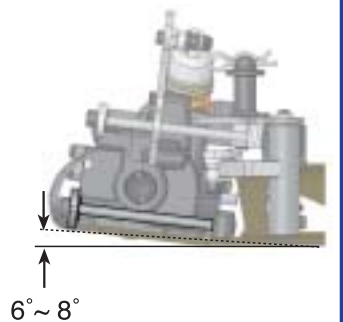





Note: Ensure you make equal adjustments on both left and right sides of the car.

SET UP

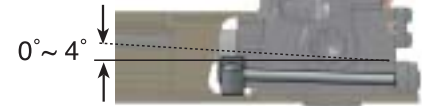
Rear Anti-Squat Adjustment

5. Rear Anti-Squat Adjustment: Adjust the rear anti-squat of the rear lower arms by replacing the different plastic arms suspension holders at the front of the rear bulkhead.







Rear susp. arm holders	Characteristics
RF 0 	Less anti-squat, flat arm Increases rear traction when cornering Decrease rear traction when accelerating.
RF2 	Easy handling on bumpy tracks ↑↓
RF3 	More anti-squat, leaning backwards Decreases rear traction when cornering
RF4 	Increases rear traction when accelerating Easy handling on smooth or slippery tracks

Camber Adjustment (Front)

6. Camber Adjustment(Front): Adjust the front camber by adjusting the lengths of threaded parts of the front pivot balls in the upper arms longer or shorter.

Length(L)	Steering Characteristics
Making longer. Positive camber.	Less steering
Making shorter. Negative camber.	More steering

Note1: To expanding the adjusting range of the front camber, you can also change the eccentric bushing in the upper plate at the very front of the front bulkhead and the mounting holes of hinge holders on the servo saver top plate.

Eccentric bushings	Servo saver top plate	Camber adjusting range of the front camber
Outer hole 		More camber adjustment
Inner hole 		Less camber adjustment

Note2: Ensure you make equal adjustments on both left and right sides of the car.

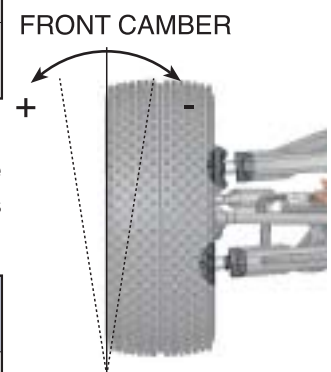

SET UP

Camber Adjustment (Rear)

7. Camber Adjustment(Rear): Adjust the rear camber by adjusting the lengths of the upper tie rods.

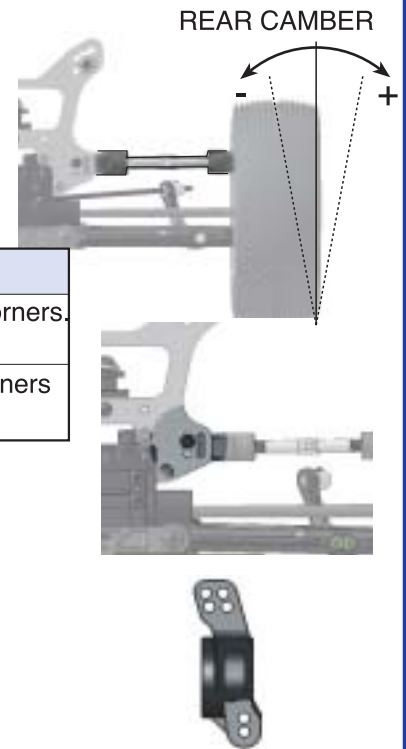

Length(L)	Steering Characteristics
Making longer. Positive camber.	Decreases traction when entering corners.
Making shorter. Negative camber.	Increases traction when entering corners

Note1: You can also adjust the rear camber by positioning the rear upper tie rods in the different holes in the shock towers and outer rear hubs. For more information, please refer to the "Set-Up Sheet" in a separate sheet.

Note2: Ensure you make equal adjustments on both left and right sides of the car.

Ride Height (or Droop) Adjustment

8. Ride Height (or Droop) Adjustment: The front/rear ride height can be adjusted by screwing in or unscrewing the setscrews in the lower arms.

Setscrews	Ride height	Characteristics
Screwing in	Becomes lower	Less steering, good handling on smooth tracks
Unscrewing	Becomes higher	More steering, good handling on rough tracks

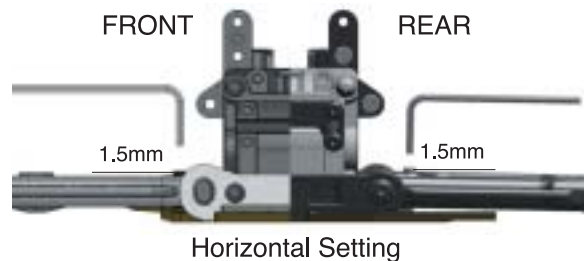

Ackerman Adjustment

9. Ackerman Adjustment: Adjust the Ackerman angle by linking the front steering rods into the different holes on the steering slider.

Steering tie-rod mounting holes	Characteristics
Forward holes	Makes the steering response milder Suitable for high speed race way.
Rearward holes	Makes the steering response sharper. Suitable for narrow, tight tracks



Note: Ensure you make equal adjustments on both left and right sides of the car.



SET UP SHEET



Name of Driver		Date	Track	Radio	Servo	Engine	Plug
Fuel		Spur/ Clutch Bell		Wheels	Tires	Inner	Muffler
Brand: Nitro: _____ %		T/ T					

SHOCKS

(Shock Oil Brand: _____)

	Front	Rear
Shaft Type	<input type="checkbox"/> Std <input type="checkbox"/> Other: _____	<input type="checkbox"/> Std <input type="checkbox"/> Other: _____
Piston		
Piston Ball	<input type="checkbox"/> 0 <input type="checkbox"/> 1 <input type="checkbox"/> 2	<input type="checkbox"/> 0 <input type="checkbox"/> 1 <input type="checkbox"/> 2
Oil	#	#
Spring	<input type="checkbox"/> Blue: Softer(3.2lb) <input type="checkbox"/> Red: Average(4.3lb) <input type="checkbox"/> Black: Harder(5.2 lb)	<input type="checkbox"/> Blue: Softer(2.7lb) <input type="checkbox"/> Red: Average(3.2lb) <input type="checkbox"/> Black: Harder(4.5lb)
Spacer	mm	mm

REBOUND STOP

Front	Rear
mm	mm

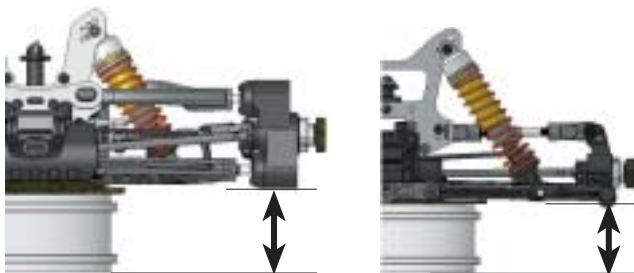

CAMBER ANGLE

Front	Rear
° Upper _____ mm,	
° Lower _____ mm	° _____ mm



WING ANGLE

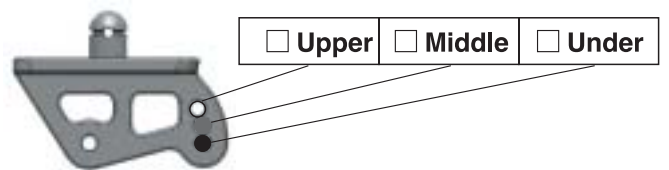

SHOCK MOUNT POSITION

Arm Mounting	Front	Rear
	<input type="checkbox"/> IN / <input type="checkbox"/> OUT	<input type="checkbox"/> IN / <input type="checkbox"/> OUT



Tower Mounting	Front	Rear
	<input type="checkbox"/> IN / <input type="checkbox"/> OUT	<input type="checkbox"/> IN / <input type="checkbox"/> OUT

FRONT ARM MOUNTING

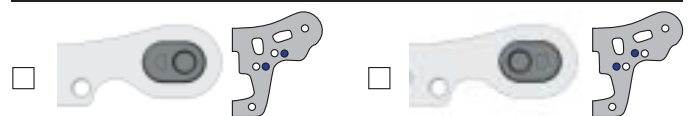

DIFF. OIL

	Front	Center	Rear
Oil #	#	#	#

TOE ANGLE

Front	Rear
° _____ mm	<input type="checkbox"/> 1, <input type="checkbox"/> 1.5, <input type="checkbox"/> 2, <input type="checkbox"/> 3

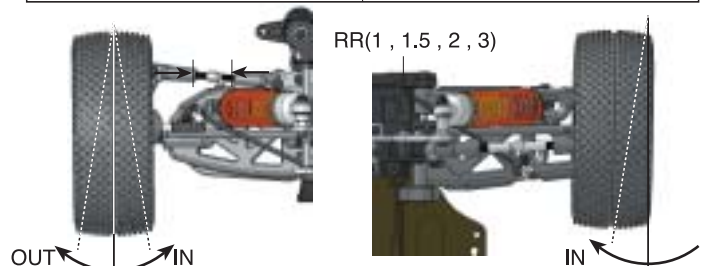

FRONT/ REAR SUSPENSION HOLDER

Front	Rear
<input type="checkbox"/> FF-1	<input type="checkbox"/> RF0
<input type="checkbox"/> FF0	<input type="checkbox"/> RF2
<input type="checkbox"/> FF1	<input type="checkbox"/> RF3
<input type="checkbox"/> FR	<input type="checkbox"/> RF4
	<input type="checkbox"/> RR1
	<input type="checkbox"/> RR1.5
	<input type="checkbox"/> RR2
	<input type="checkbox"/> RR3

REAR UPPER ARM POSITION

1. Rear Hub Position
2. Upper Arm Position
3. Upright Pin Position

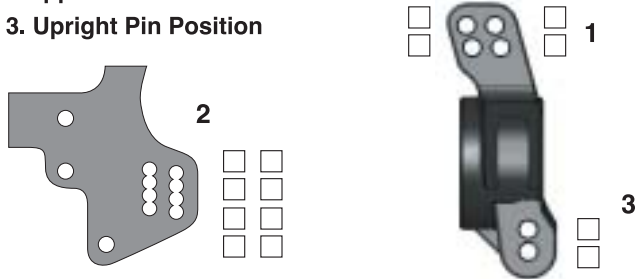

FRONT CASTER

Spacer:	
Front:	mm
Rear:	mm

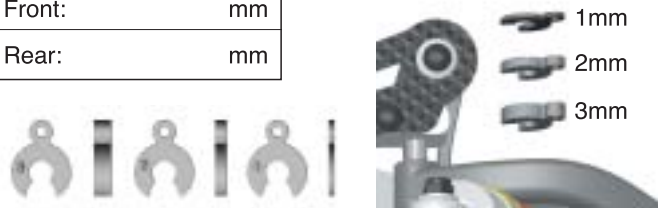

RACE NOTE

Main: _____ Place TQ _____
 Notes: _____

STEERING PLATE

A: Front

B: Rear



SWAY BAR

Front	Gold ø3	Black ø2.7	Silver ø2.5
Rear	Gold ø3	Black ø2.7	Silver ø2.5

TRACK WIDTH



WHEELBASE ADJUSTMENT

Spacer:	
Front:	mm
Rear:	mm



TRACK CONDITIONS

Surface: Smooth Bumpy

Bumps: _____

Traction: Low Med High

Composition: _____

Sandy Soft Dirt Grass Clay Other

Wet Dry Dusty Other